

1999

## Taxable and Tax-Free Acquisitions and Separations

Mark J. Silverman

Robert H. Wellen

Mark L. Yecies

---

### Repository Citation

Silverman, Mark J.; Wellen, Robert H.; and Yecies, Mark L., "Taxable and Tax-Free Acquisitions and Separations" (1999). *William & Mary Annual Tax Conference*. 369.  
<https://scholarship.law.wm.edu/tax/369>

45th WILLIAM & MARY TAX CONFERENCE

TAXABLE AND TAX-FREE ACQUISITIONS AND SEPARATIONS

December 3, 1999

Mark J. Silverman  
Steptoe & Johnson LLP  
Washington, D.C.

Robert H. Wellen  
Ivins, Phillips & Barker  
Washington, D.C.

Mark L. Yecies  
Ernst & Young LLP  
Washington, D.C.

## TABLE OF CONTENTS

### **I. TAXABLE TRANSACTIONS**

Applicable Asset Acquisition .....	1
Section 338.....	6
Section 338(h)(10) .....	7
Section 338 -- Purchase/Has a Corporation Made the Purchase.....	8
Section 338 -- Purchase/Common Ownership of S and P .....	12
Application of Section 338 to the Purchase of an Insolvent Corporation -- Insolvent Target Corporation.....	13
Section 338 -- Purchase/Cash Investment.....	14
Section 338 -- Purchase/Cash Investment Followed by Redemption .....	15
Section 338 Election Rules -- Chain of Corporations.....	16
Section 338(h)(10) Election History .....	17
Section 338(h)(10) Election Factors .....	18
Eligibility .....	19*
Qualified Stock Purchase Acquisition from T .....	20
Qualified Stock Purchase -- Going Public Using Section 338(h)(10) .....	21
Qualified Stock Purchase -- Becoming Related .....	24
Procedure .....	25
Section 338(h)(10) Model.....	26
Seller's Side.....	27
Buyer's Side .....	28
Subsequent Adjustments.....	29
Special Issues -- Tier Allocation -- Bargain Purchase .....	30
Special Issues -- Tier Allocation -- Effect of Liabilities.....	32
Tier Allocation.....	33
Special Issues -- Insolvent T .....	34
Special Issues -- Insolvent Subsidiary .....	35
Section 338(h)(10) -- Other Items.....	36
Pre-Sale Distribution.....	37
Minority Shareholders .....	38
Use of LLC .....	39
Contingent Liabilities -- Is it an assumed obligation - Factors .....	40
Consequences of an Assumed Liability .....	41
Contingent Liabilities -- Section 338(h)(10) .....	42
Contingent Liabilities .....	44

## **II. ZERO BASIS ISSUES**

Prop. Treas. Reg. § 1.1032-3 Property Acquisition – Basic Example.....	45
Prop. Treas. Reg. § 1.1032-3 Property Acquisition – Basic Example with Options.....	46
Prop. Treas. Reg. § 1.1032-3 Employee Compensation – Basic Example.....	47
Prop. Treas. Reg. § 1.1032-3 Employee Compensation – Reversionary Interest.....	48
Section 1032 Contribution by X to Partnership – TAM 9822002.....	49
Section 1032 The Immediacy Requirement – TAM 199901003.....	50

## **III. SECTION 351(g) and Section 357**

Section 351(g) Appreciated Property.....	52
Section 351(g) Loss Property -- Nonqualified Preferred Stock.....	53
Section 351(g) Loss Property -- Nonqualified Preferred Stock and Common Stock.....	54
B Reorganization.....	55
Disqualified Preferred Stock?.....	56
Disqualified Preferred Stock? -- Alternative 1.....	57
Disqualified Preferred Stock? -- Alternative 2.....	58
Exchange of Stock for Nonqualified Preferred Stock.....	59
Section 351(g) -- Section 304.....	60
Sections 357 and 358.....	61

## **IV. TAX-FREE TRANSACTIONS**

### **Continuity of Interest:**

Quantitative Continuity.....	64
Changes in Price.....	65
PLR 9838007.....	68
Post-Reorganization Continuity.....	69
Pre-Reorganization Continuity And Redemption Transactions.....	70
Pre-Reorganization Continuity -- Public Market Buyback Program.....	71
PLR 199935042.....	72
Buyback Issues (Alternatives).....	74
Examples Regarding Stock Buybacks.....	75
Maintaining Direct Or Indirect Interests In The Target Corporation.....	77
Yoc Heating.....	78
Old Treas. Reg. § 1.368-1(e)(6), Example 2.....	79
New Treas. Reg. § 1.368-1(e)(6), Example 2.....	80
Pre-Reorganization Continuity And Redemption Transactions.....	81

## **Continuity of Business Enterprise**

Asset Transfers To Corporations .....	82
Continuity of Business Enterprise: Cross-Chain Transfers .....	83
Continuity of Business Enterprise: Cross-Chain Transfers .....	84
Continuity Of Business Enterprise.....	85
Continuity Of Business Enterprise.....	86
Transfers to Partnerships.....	87
Transfers to Partnerships.....	88
Continuity Of Business Enterprise -- Transfers to Partnerships.....	89
Transfers of Stock To Partnerships.....	90
Aggregation Of Partnership Interests.....	91
Tiered Partnerships .....	92

## **Other Reorganization Problems**

"Substantially All" .....	93
"Control" for Voting Stock .....	96
Bausch & Lomb .....	102

## **Tax-Free Spin-Offs**

Section 355 -- Expansion -- PLR 199937014 .....	105
Basic Morris Trust Structure.....	106
Section 355(e) Applies.....	107
Section 355(e) Inapplicable .....	108
Spin-off and Acquisition.....	109
Section 355(f) Applies .....	113
Section 355(f) Applies -- Alternative .....	114
Section 355(g).....	115
Section 355(d) In General .....	116
Multiple Spin-Offs (Triple Tax Potential) .....	117
Public Offering.....	118
Elimination of Basis.....	119
Purchase Taint From Tax-Free Transaction .....	120
Holding Company Formation .....	121

## **V. USE OF SINGLE-MEMBER LLCs:**

Single Member LLCs In General.....	122
Multiple Disregarded Entities .....	124
Merger of Corporation Into Single-Member LLC .....	125
Sale of All of the Membership Interests .....	126
Sale of Less than All of the Membership Interests .....	127
Conversion of Multi-Member LLC into Single Member LLC in Consolidation .....	128

Use of LLCs to Avoid Section 338(h)(10) Limitations .....	129
B Reorganization .....	132
C Reorganization .....	133
A Reorganization .....	134
Downstream Merger into LLC.....	135
Downstream Merger into LLC -- Variation 1.....	136
Downstream Merger into LLC -- Variation 2.....	137
Intragroup A Reorganization .....	138
Use of LLCs in Spin-Offs.....	139
Distribution of LLC interests as a Spin-Off.....	141
Avoiding the Requirements of Section 355 .....	142
Section 355(e) Transaction .....	143

# Applicable Asset Acquisition

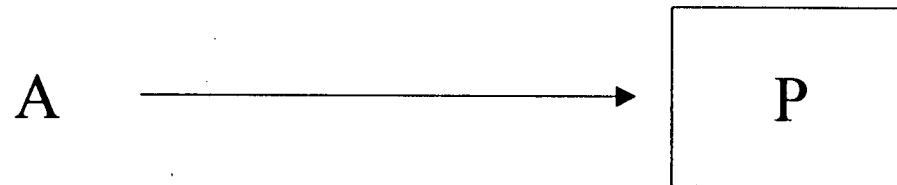

	<u>FMV</u>	<u>Basis</u>
Land	\$150,000	\$100,000
Building	\$250,000	\$0
Covenant Not to Compete	\$100,000	

Does section 1060 apply?

Do the assets constitute a trade or business?

# Applicable Asset Acquisition Continued

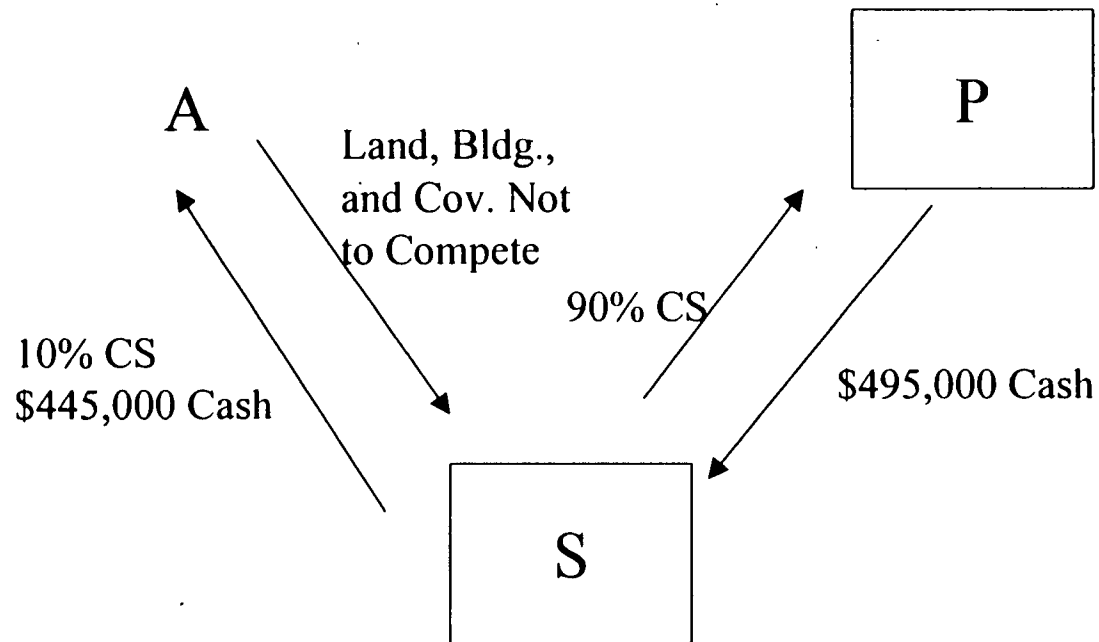

Section 1060 does not apply.



# Applicable Asset Acquisition Continued

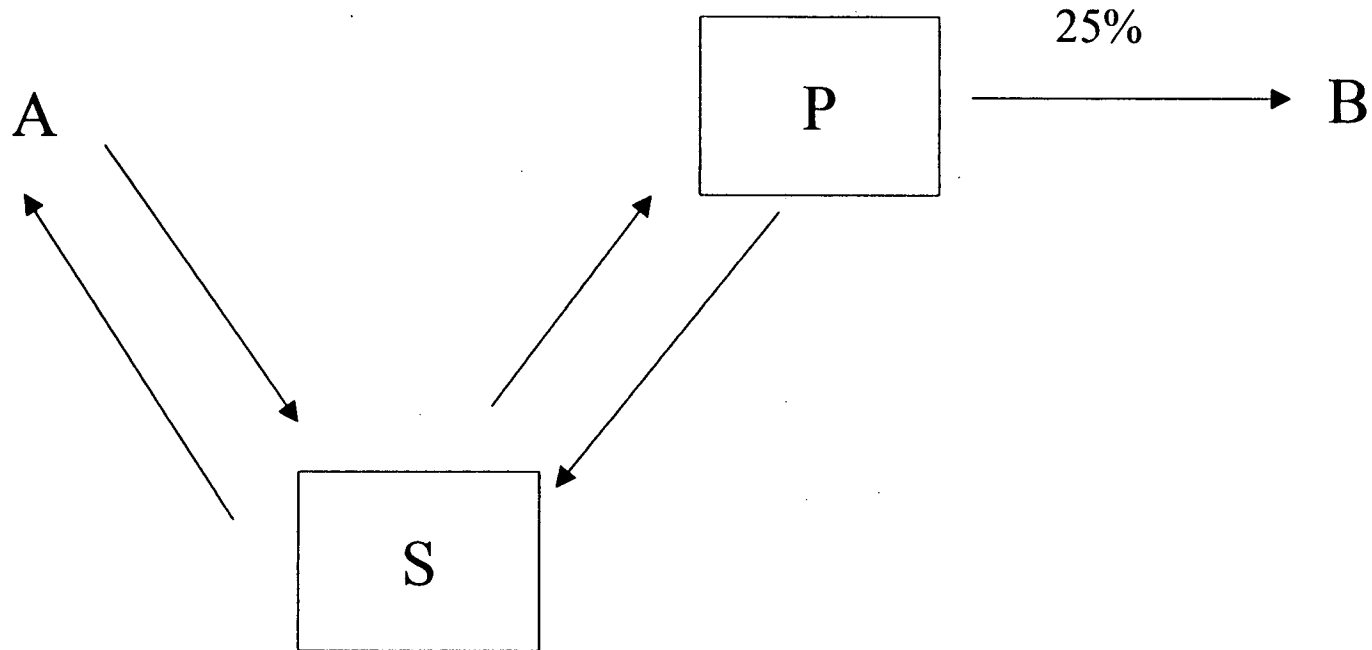

Busted section 351; section 1060 applies.

# Applicable Asset Acquisition Continued

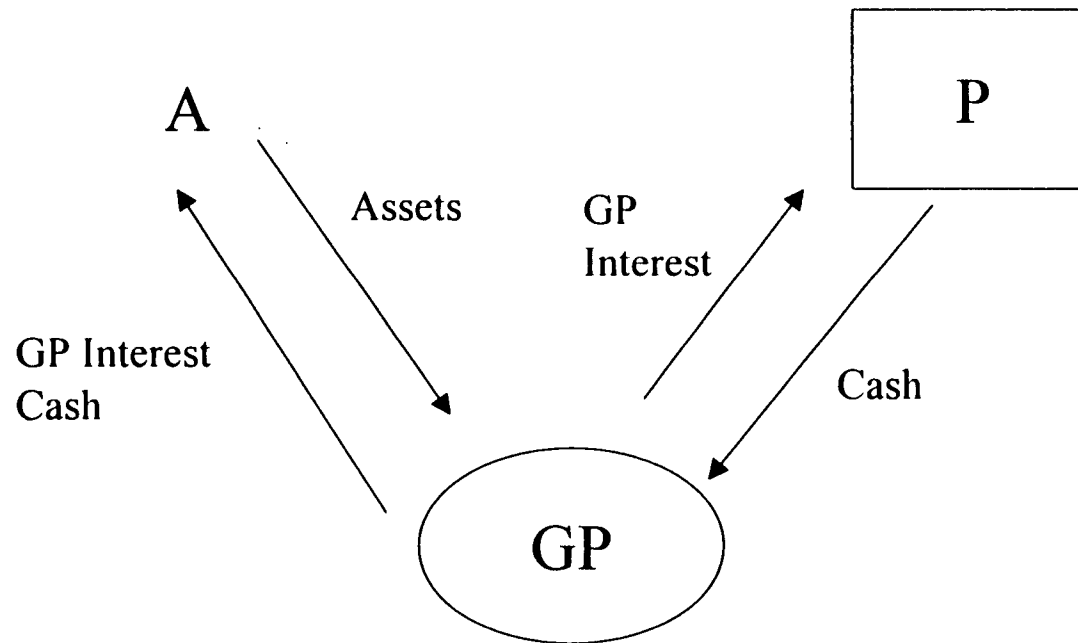

Section 707(a)(2)(B).

# Applicable Asset Acquisition Continued

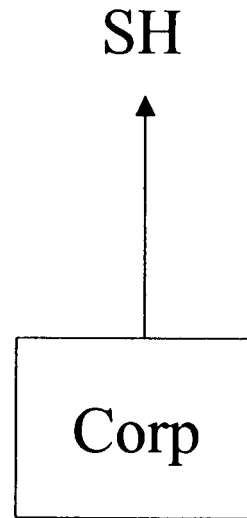

1. Corporation liquidates.
2. Section 302(a) redemption.
3. Section 301 distribution.

# Section 338

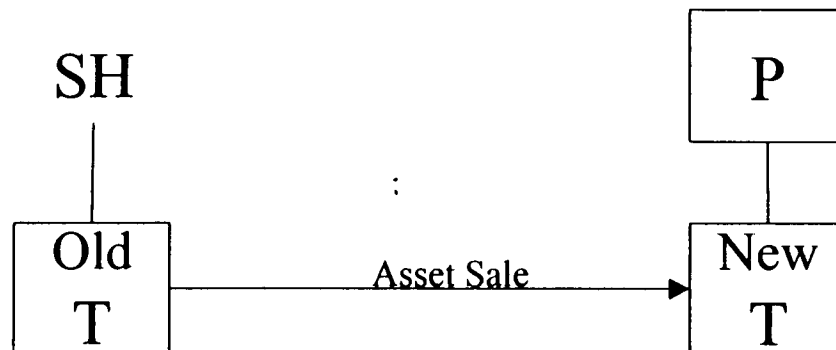
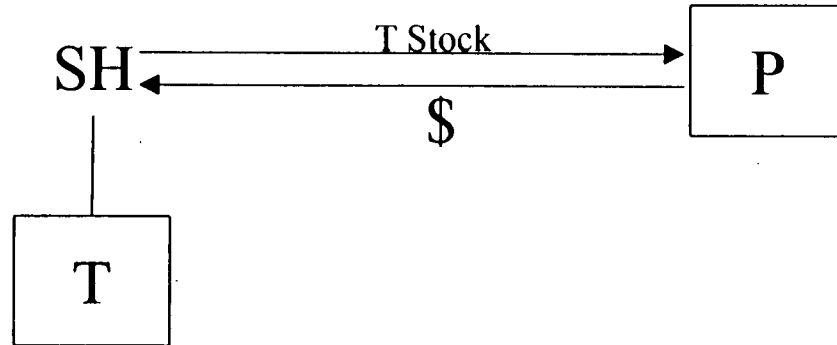

# Section 338(h)(10)

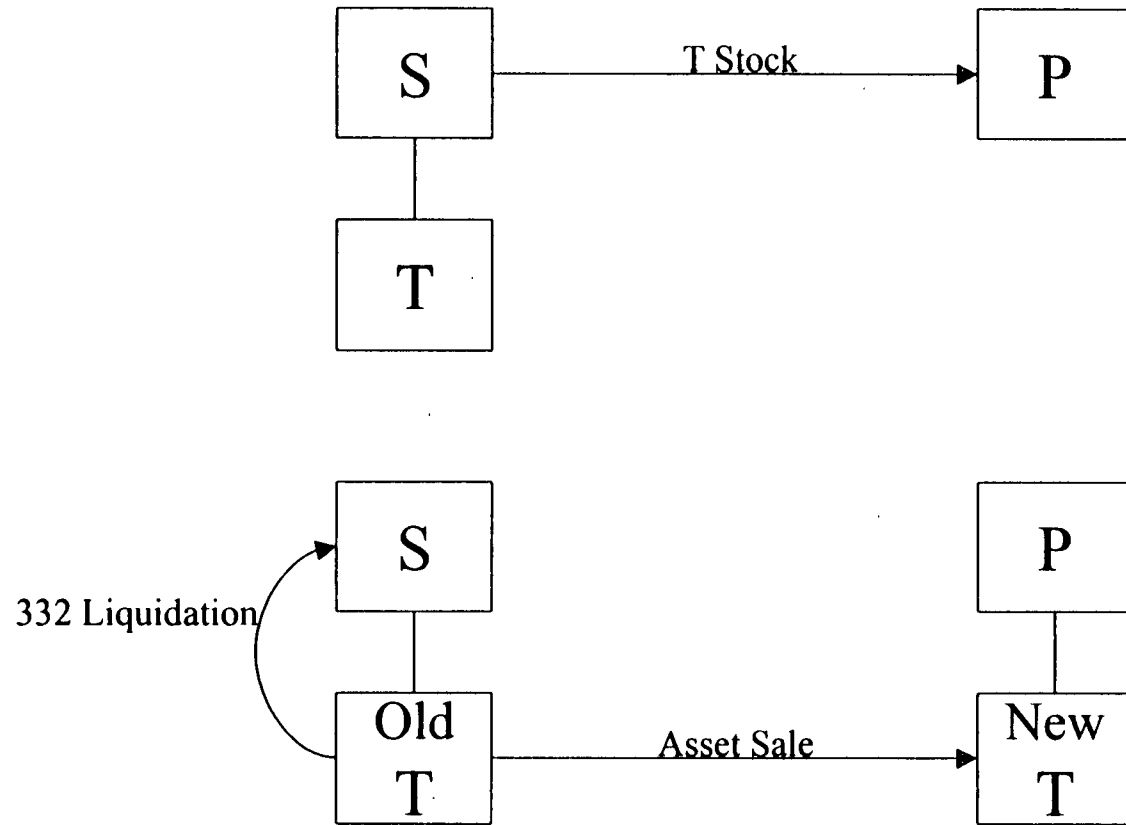

## Section 338 -- Purchase

### Has a Corporation Made the Purchase

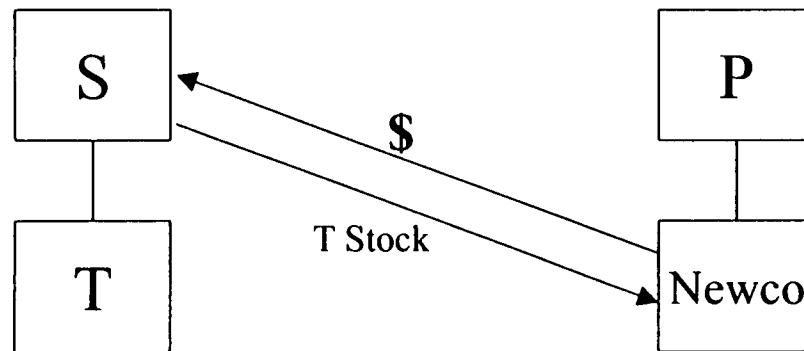

1. Newco buys T stock from S.

# Section 338 -- Purchase Continued

## Has a Corporation Made the Purchase

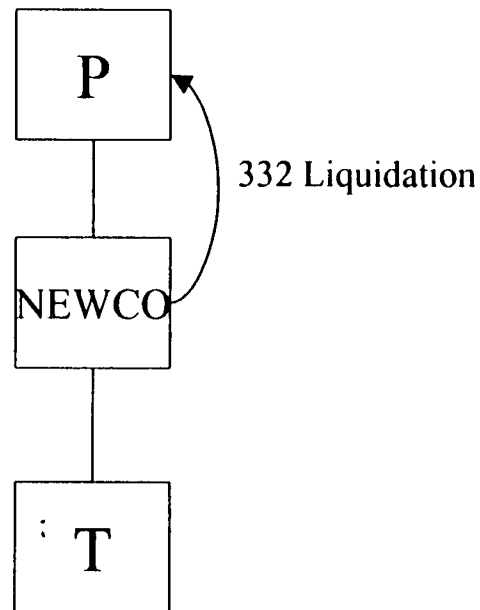

2. Newco is liquidated into P.

## Section 338 -- Purchase Continued

### Has a Corporation Made the Purchase

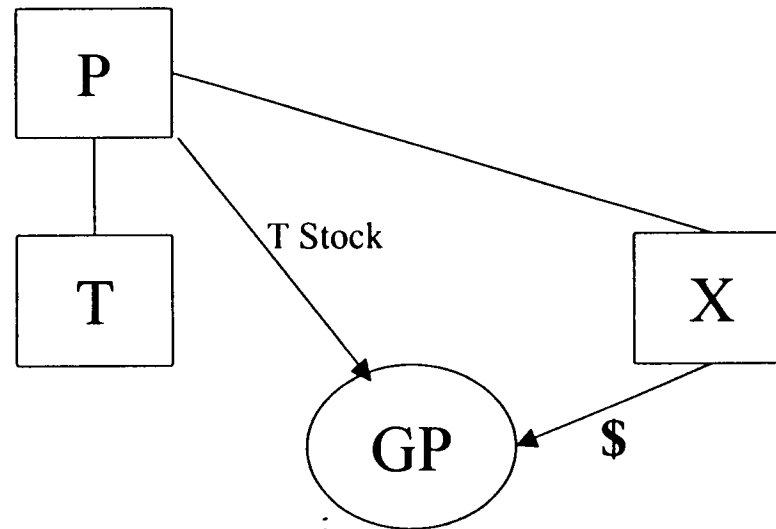

3. P and X form a partnership. P transfers the T stock to the partnership.



# Section 338 -- Purchase Continued

## Has a Corporation Made the Purchase

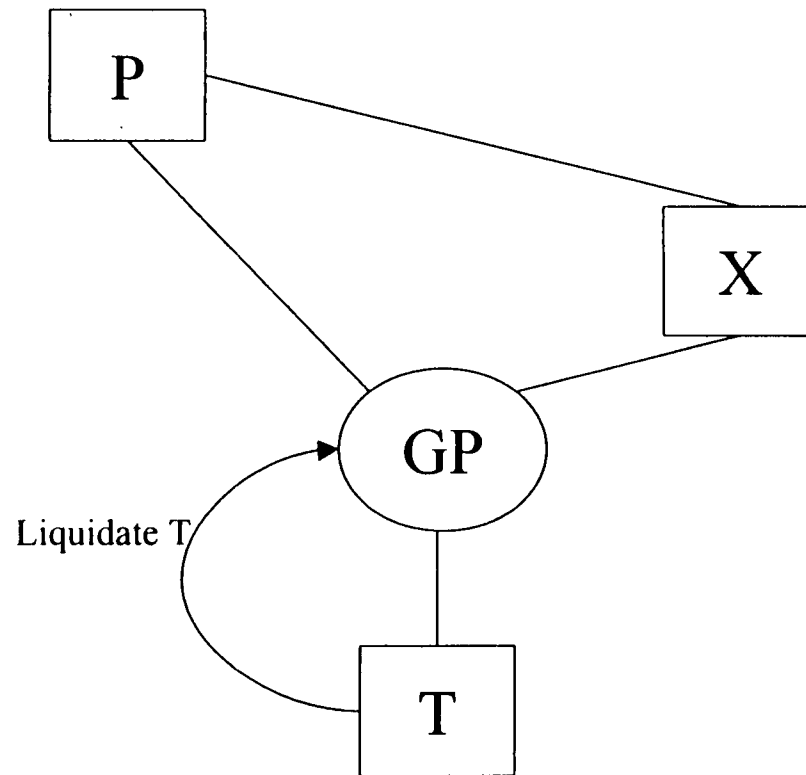

# Section 338 -- Purchase

## Common Ownership of S and P

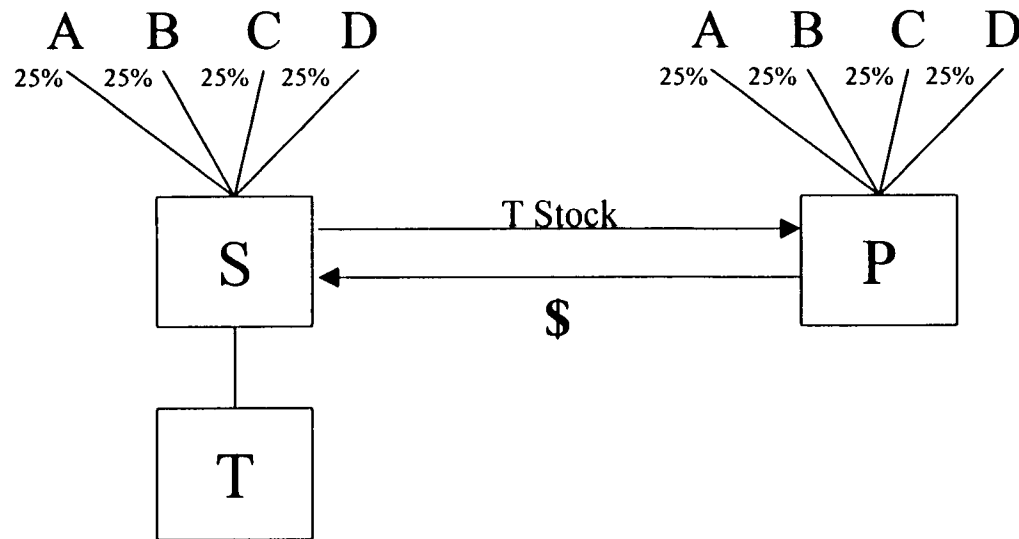

Has P purchased the T stock?

# Application of Section 338 to the Purchase of an Insolvent Corporation -- Insolvent Target Corporation

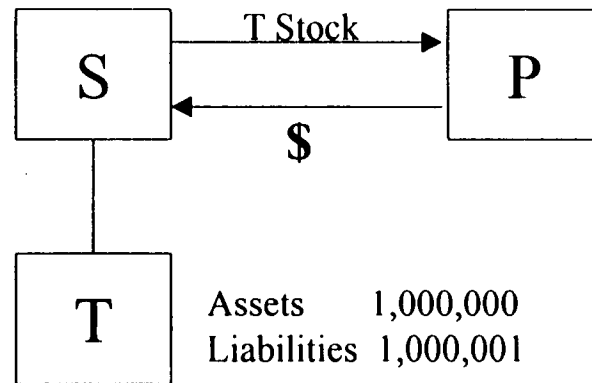

## **Facts**

Corporation T owns assets with a value of \$1,000,000 and has liabilities of \$1,000,001. P purchases all the stock of T from S for \$1 and attempts to make a section 338(g) election with respect to T.

## **Questions**

1. What are the results of this election?
2. Would the result be different under the proposed section 338 regulations?

## **References**

Section 338(h)(3)(A)  
Treas. Reg. § 1.332-2(b)  
Prop. Treas. Reg. § 1.338-3(b)(2)  
Prop. Treas. Reg. § 1.338(h)(10)-1(d)(4)  
Rev. Rul. 56-387, 1956-2 C.B. 189

# Section 338 -- Purchase

## Cash Investment

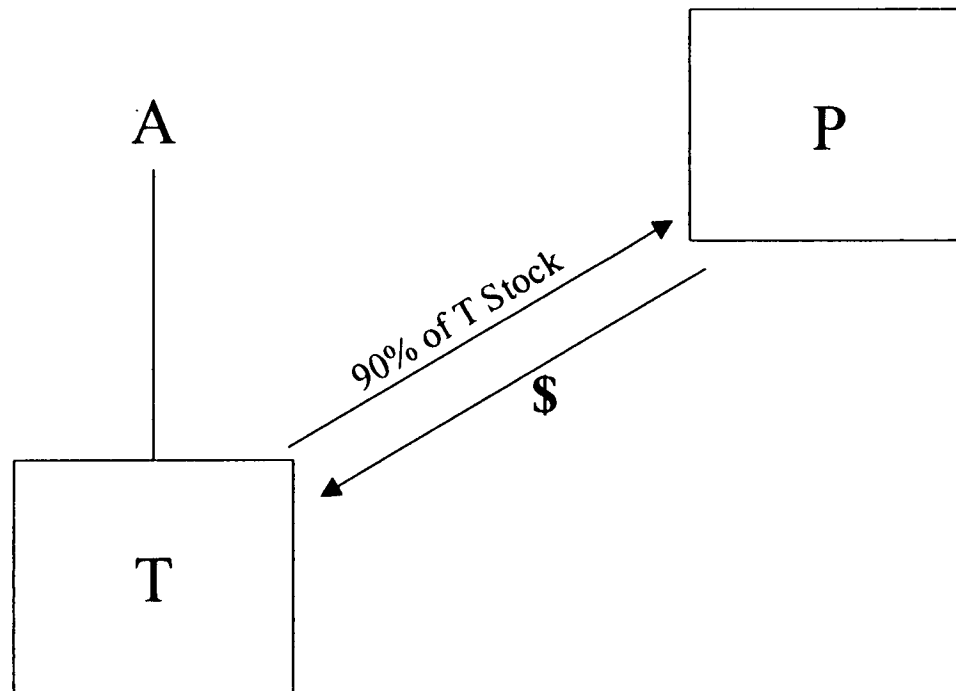

1. A owns all T stock.
2. P transfers cash to T for 90% of T stock.
3. Has P purchased the T stock?

## Section 338 -- Purchase

### Cash Investment Followed by Redemption

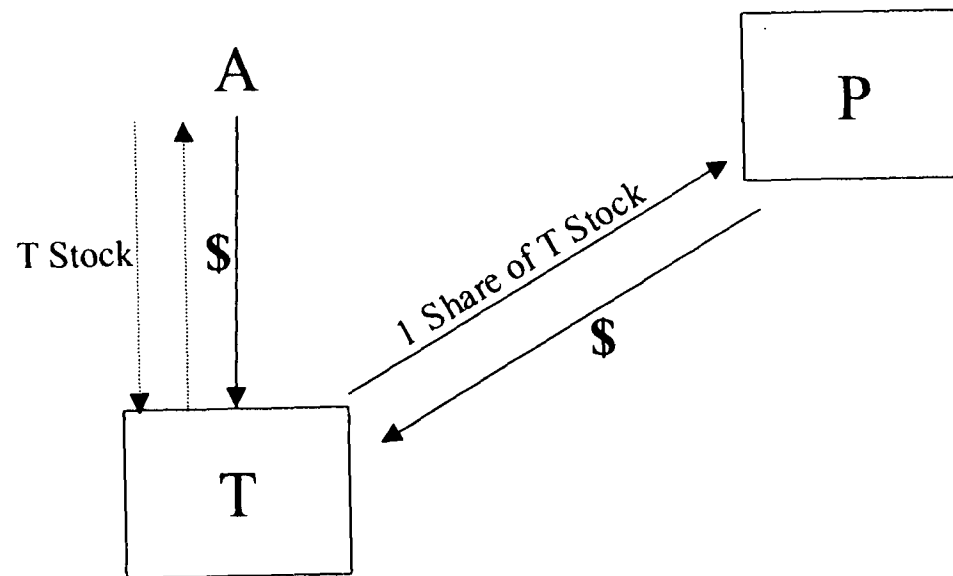

1. A owns all T stock.
2. P transfers cash to T for 1 share of T stock.
3. A is redeemed by T (using funds other than those provided by P).
4. Has P purchased the T stock?

# Section 338 Election Rules

## Chain of Corporations

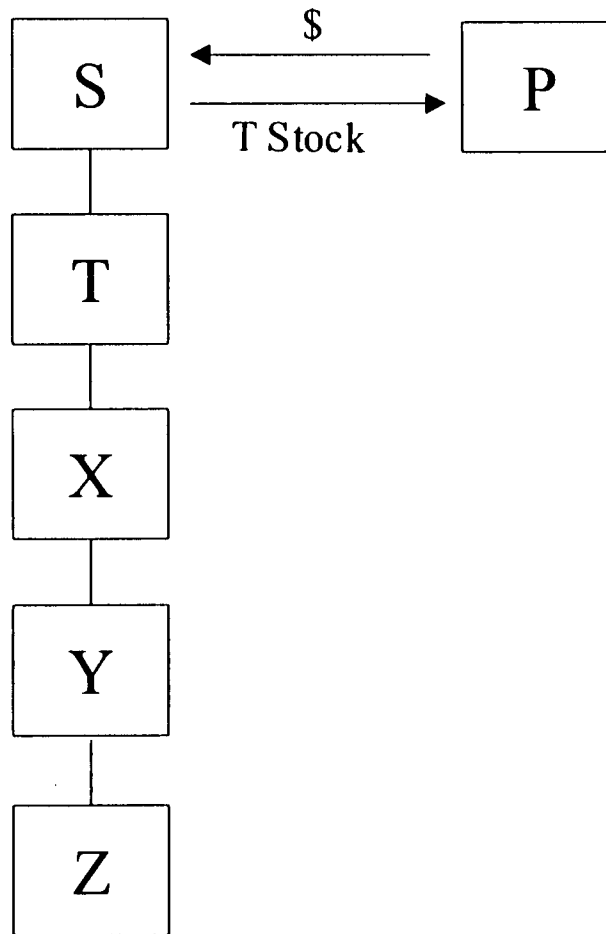

1. P purchases the stock of T from S and makes a section 338 election for T.
2. May P make a section 338 election for X, Y, and Z?
3. May P make a section 338(h)(10) election for X, Y, and Z?

# Section 338(h)(10) Election History

---

- Legislation
- Regulations

## Section 338(h)(10) Election Factors

---

- Desire for stock transaction
- Net inside basis vs. outside basis
- LDR
- Amount of basis step up
- Allocation of basis step up
- Ability to use basis step up
- Existence of T NOL
- Minority ownership
- Recap accounting



# Eligibility

---

- Consolidated subsidiary
- Nonconsolidated affiliated subsidiary
- S corporations
- Qualified stock purchase

# Qualified Stock Purchase Acquisition From T

---

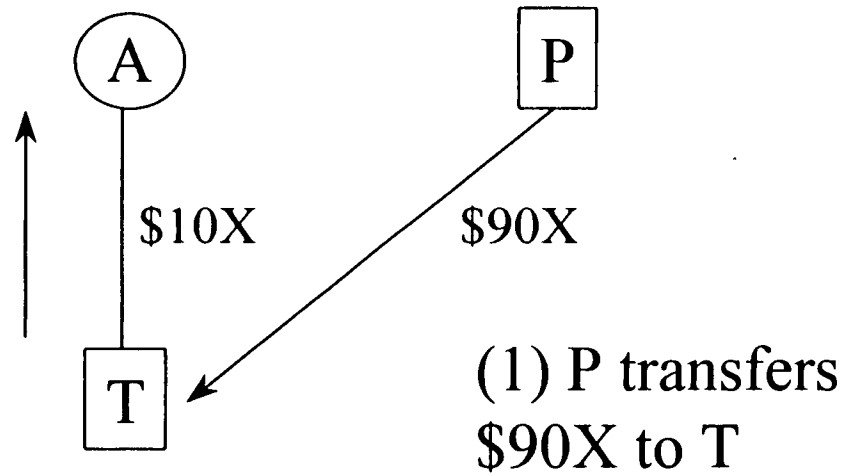

(2) (Perhaps) T distributes \$8X to A

# Qualified Stock Purchase Going Public Using §338(h)(10)

---

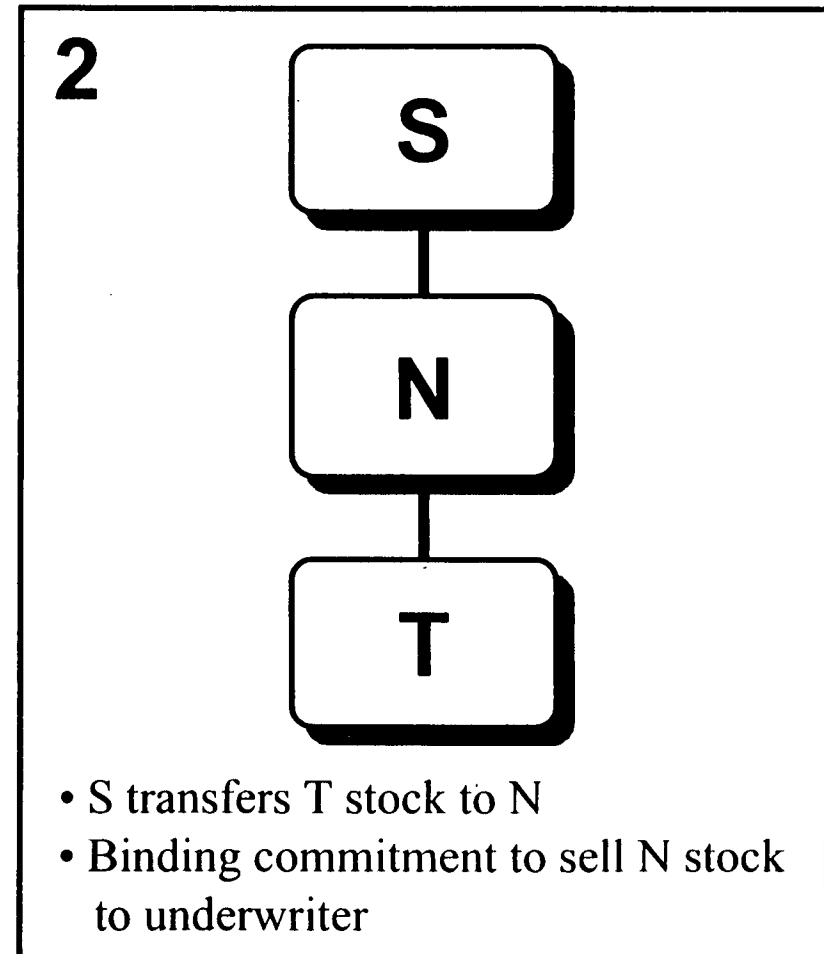
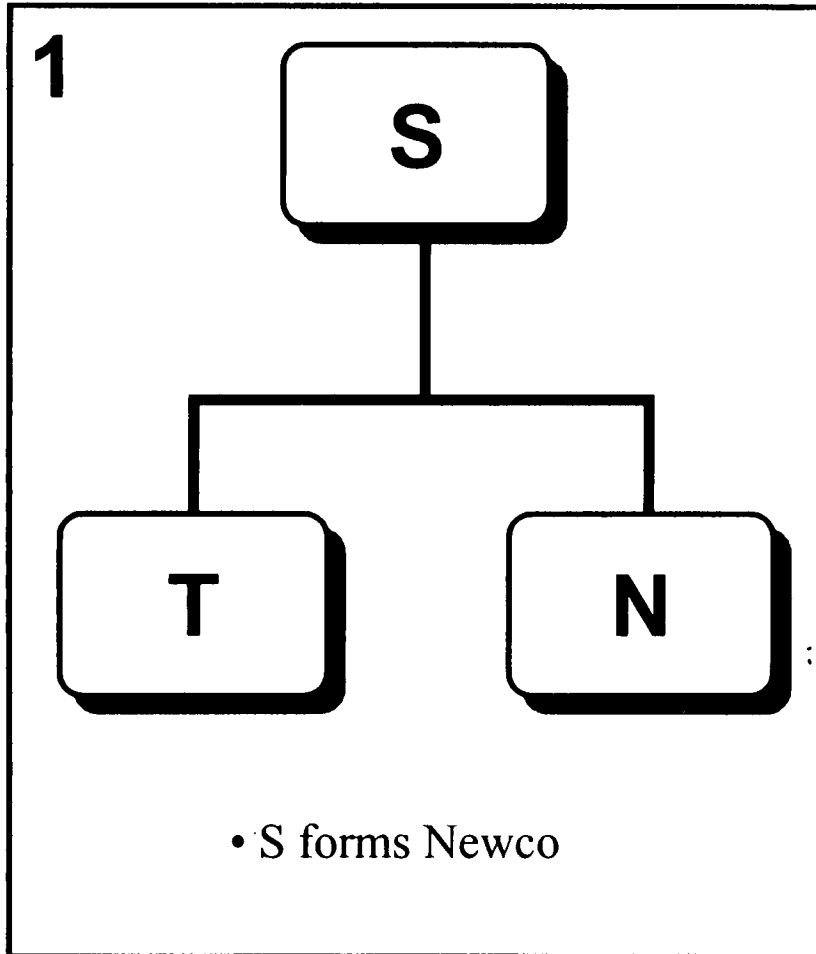

# Going Public Using §338(h)(10) (cont'd)

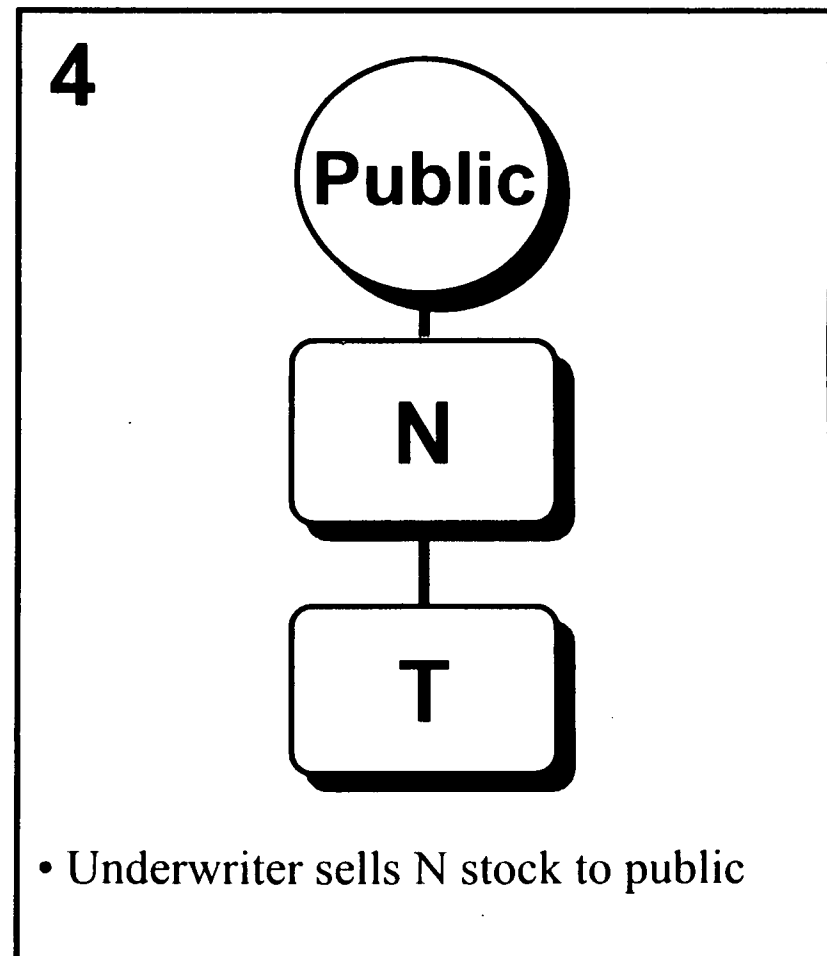
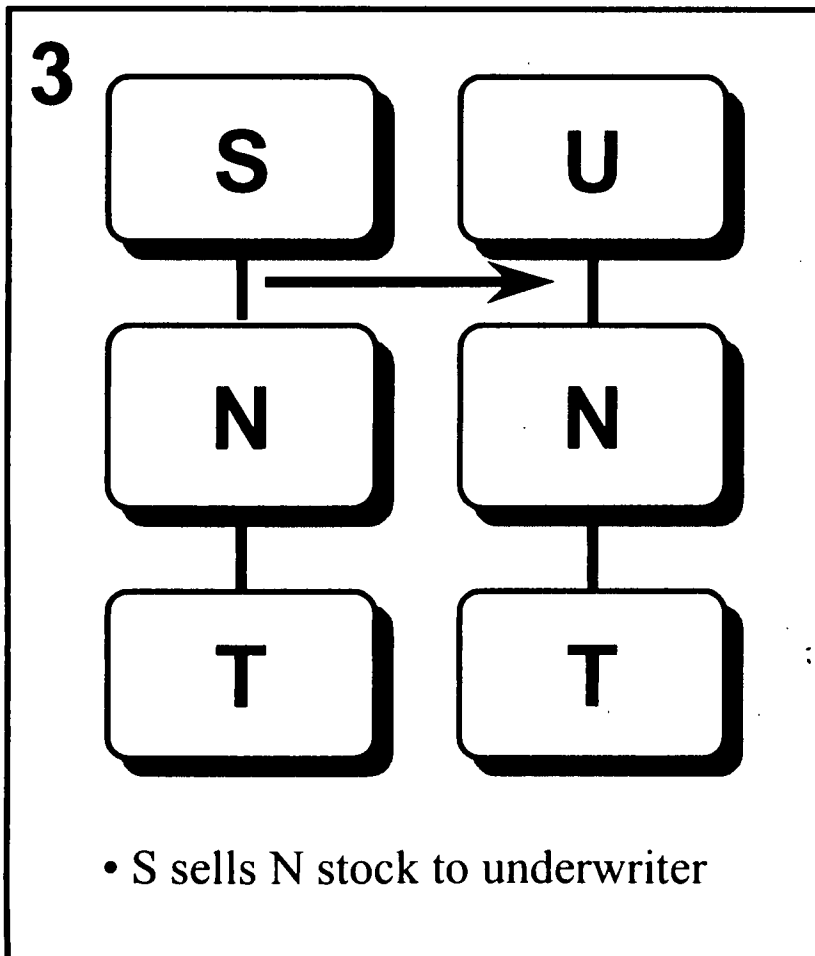

# Going Public Using §338(h)(10) (cont'd)

---

- Prop Reg §1.338-3(b)(3)(iv), Example 1
- Tech Advice 9747001; PLR 9142013, 9541039
- B reorganization exposure
- Concurrent Primary Offering by N
  - Reg. §1.351-1(a)(3)
  - Rev. Rul. 79-194
- §197 Anti-churning exposure

# Qualified Stock Purchase Becoming Related

---

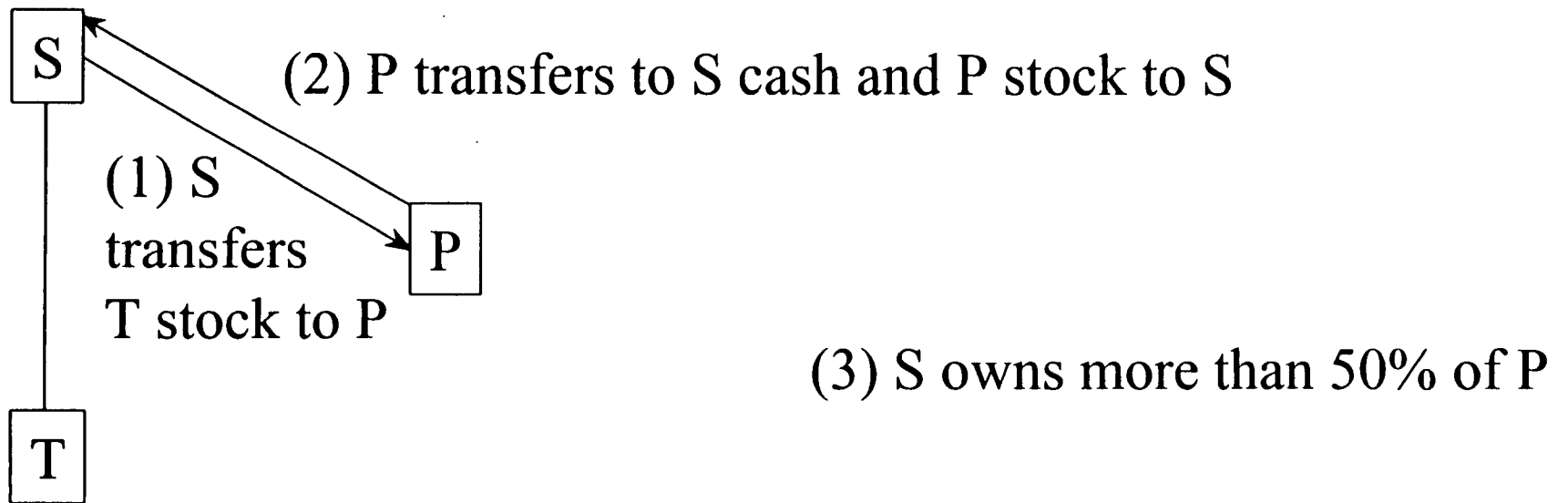

# Procedure

---

- Joint election
- 8 1/2 months -- 9100 relief
- Form 8023

# Section 338(h)(10) Model

---

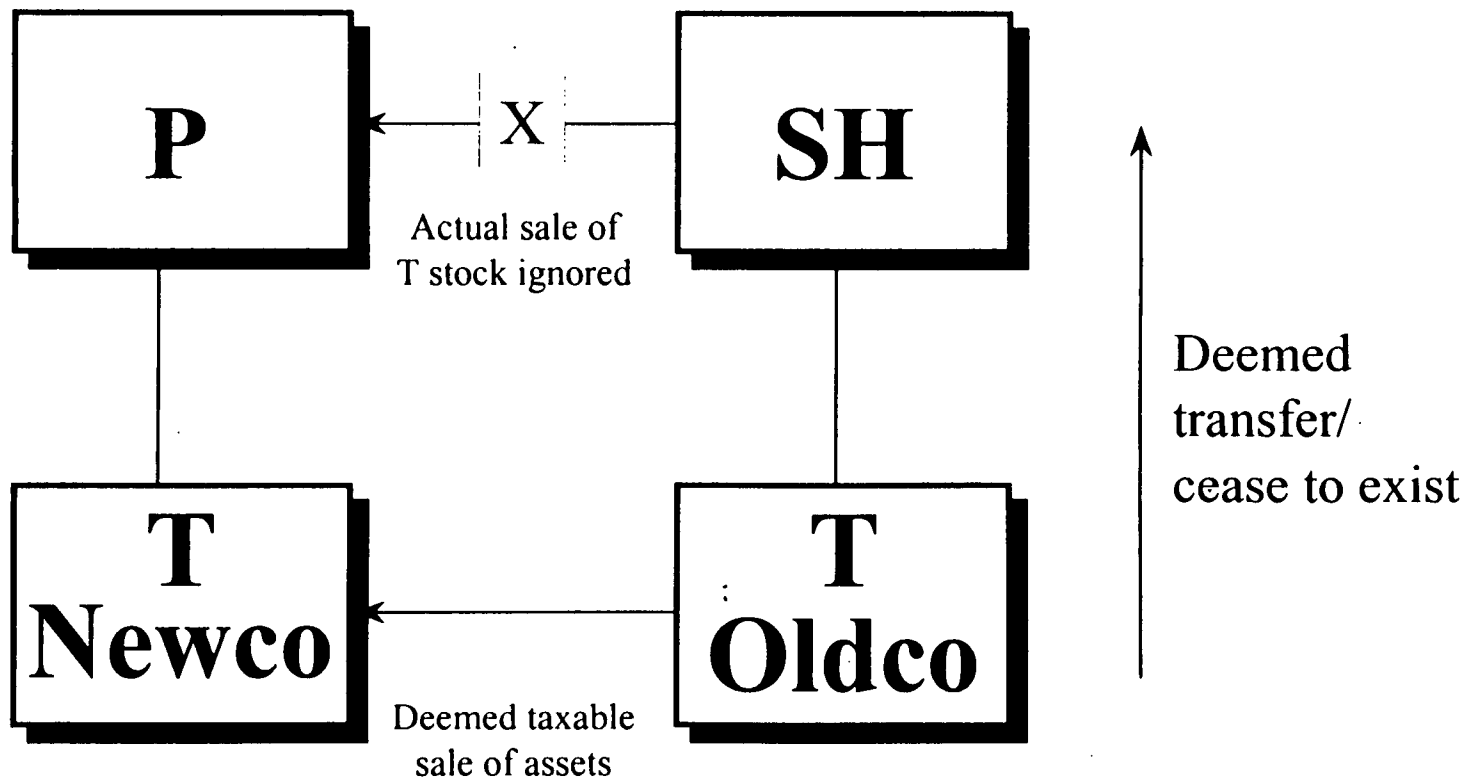



## Seller's Side

---

- Deemed Sale
- [M] ADSP
- Deemed “liquidation”
- Installment reporting
- Prior deferred gain on T Stock

# Buyer's Side

---

- Treatment as a new corporation
- Basis
  - AGUB
  - Allocation - Classes
- Several tax liability
- Non-consolidated T

# Subsequent Adjustments

---

- Contingent Payments
  - Current Regulations
  - Proposed Regulations
- Contingent Liabilities
  - Current Regulations
  - Proposed Regulations

# Special Issues

## Tier Allocation -- Bargain Purchase

---

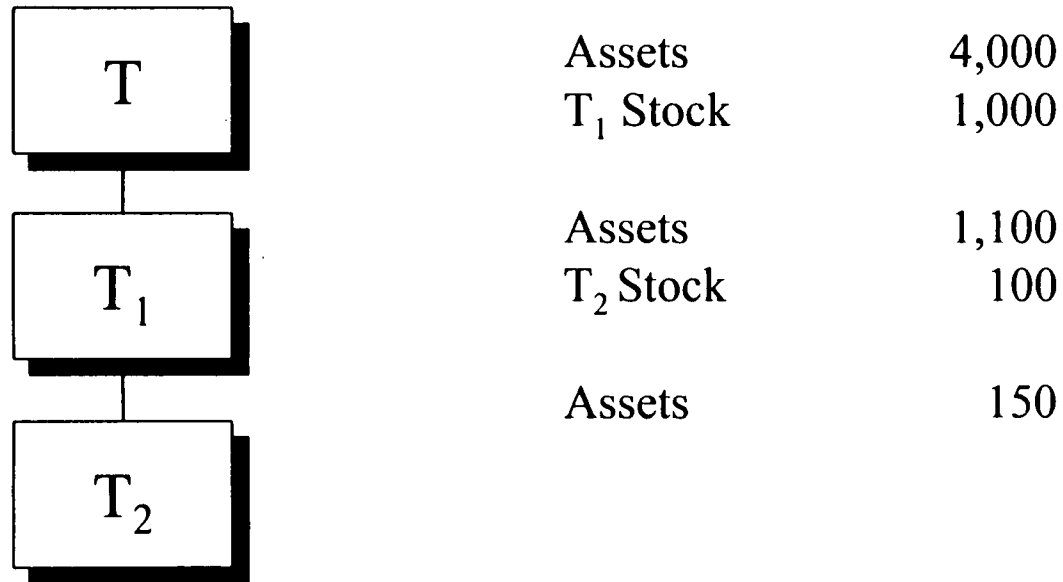

Purchase Price	4,500	
All Assets in T		
T    4,000/5,250	X 4,500 =	3,428
T <sub>1</sub> 1,100/5,250	X 4,500 =	942
T <sub>2</sub> 150/5,250	X 4,500 =	128

## Tier Allocation -- Bargain Purchase

---

$$\text{T Assets } 4,000/5,000 \times 4,500 = 3,600$$

$$\text{T}_1 \text{ Stock } 1,000/5,000 \times 4,500 = 900$$

$$\text{T}_1 \text{ Assets } 1,100/1,200 \times 900 = 825$$

$$\text{T}_2 \text{ Stock } 100/1,200 \times 900 = 75$$

$$\text{T}_2 \text{ Assets } \quad \quad 75$$

		<u>Tier</u>	<u>Base</u>
T	=	3,600	3,428
T <sub>1</sub>	=	825	942
T <sub>2</sub>	=	75	128

# Tier Allocation -- Effect of Liabilities

---

T	Assets	4,000
	T <sub>1</sub> Stock	1,250
T <sub>1</sub>	Assets	2,000
	T <sub>2</sub> Stock	250
	Liabilities	1,000
T <sub>2</sub>	Assets	1,250
	Liabilities	1,000

Purchase Price                   4,500

All Assets (7,250) and Liabilities (2,000) in T

T	4,000/7,250	X 6,500 =	3,587
T <sub>1</sub>	2,000/7,250	X 6,500 =	1,793
T <sub>2</sub>	1,250/7,250	X 6,500 =	1,120

# Tier Allocation

---

T Assets	4,000/5,250	x	4,500	=	3,428
T <sub>1</sub> Stock	1,250/5,250	x	4,500	=	1,072
———Add 1,000 T <sub>1</sub> Liabilities———					
T <sub>1</sub> Assets	2,000/2,250	x	2,072	=	1,842
T <sub>2</sub> Stock	250/2,250	x	2,072	=	230
T <sub>2</sub> Assets	230	+	1,000 Liabilities	=	1,230

			<u>Tier</u>		<u>Base</u>
T	=		3,428		3,587
T <sub>1</sub>	=		1,842		1,793
T <sub>2</sub>	=		1,230		1,120





# Special Issues -- Insolvent Subsidiary

---

T	Assets	10,000,000
	Liabilities	6,000,000
T <sub>1</sub>	Assets	1,000,000
	Liabilities	1,100,000
T <sub>2</sub>	Assets	1,000,000,000
	Liabilities	999,999,999

## Section 338(h)(10) -- Other Items

---

- Pre-sale distribution
- Minority shareholders
- Use of LLCs

# Pre-Sale Distribution

---

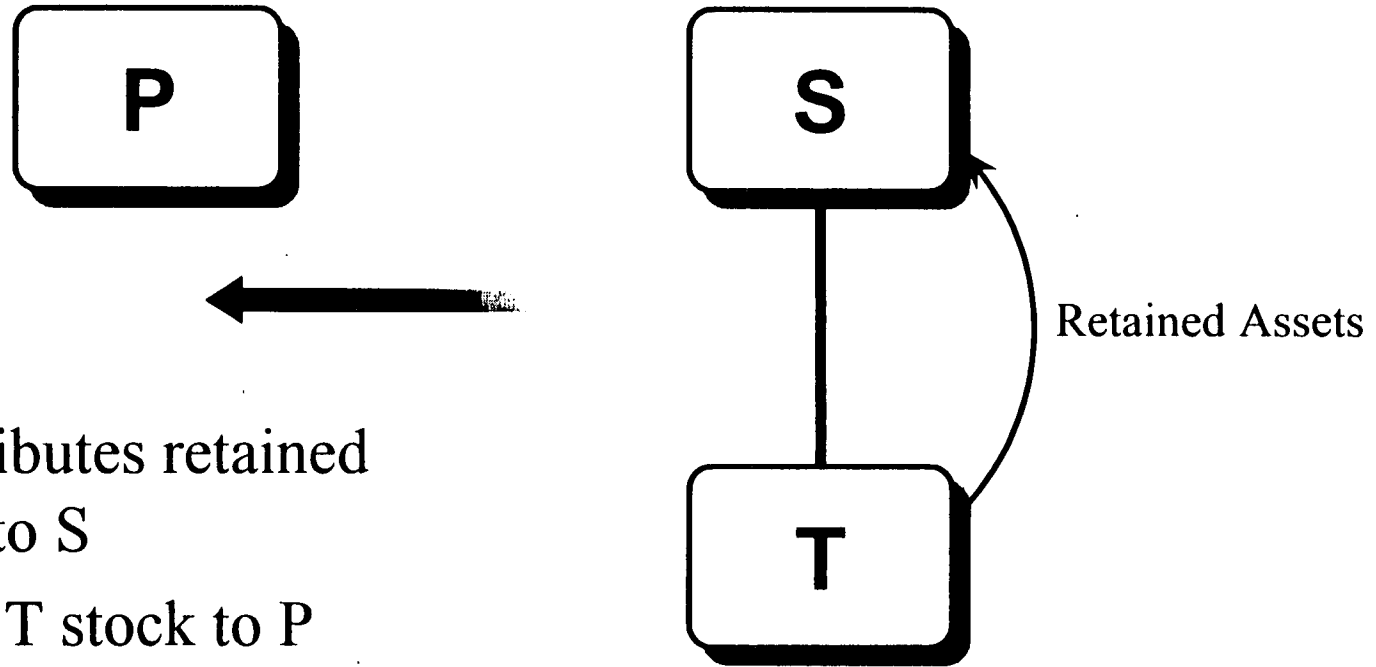

- T distributes retained assets to S
- S sells T stock to P
- P and S join in §338(h)(10) election
- Prop. Reg. §1.338(h)(10) - 1(e), Example 2
- Reincorporation

# Minority Shareholders

---

- Results to nonselling S corporation shareholders.
- Results where Parent owns less than 100% of T.
- Results where Parent sells less than 100% of T.

# Use of LLC

---

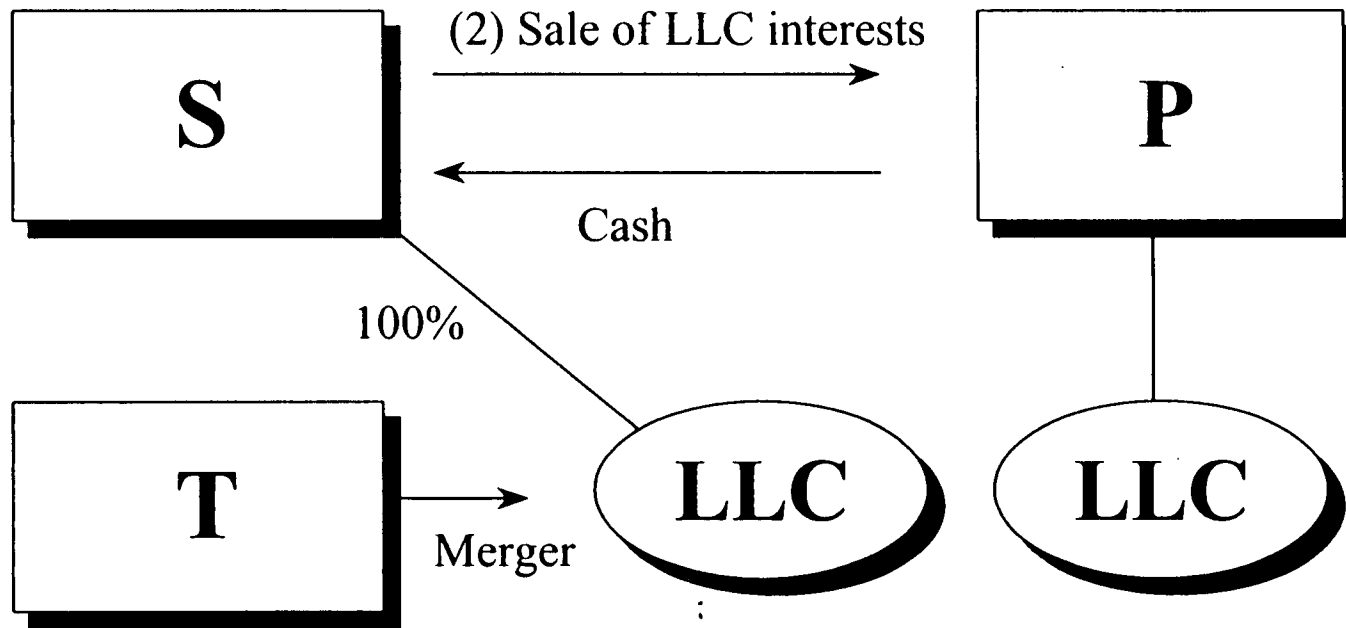

- T converts to LLC
- S sells 100% of LLC interests to P
- Treated as asset sale from S to P

**CONTINGENT LIABILITIES**  
**IS IT AN ASSUMED OBLIGATION – FACTORS**

- **Results from Buyer's Operation**
- **Arises Out of Post-Acquisition Events**
- **Buyer Aware of Liability**
- **When Did Legal Liability Arise**
- **Reflection in Price**
- **Express Assumption by the Buyer**
- **Balance Sheet Reserve**

# **CONSEQUENCES OF AN ASSUMED LIABILITY**

## **TO THE SELLER**

**Income Inclusion – When**

**What Amount**

- **Installment Reporting**
- **Offsetting Deduction**
- **Imputed Interest Income**

## **TO THE BUYER**

**Capitalize Payment :**

- **Deduct Payment**
- **Report Income**
- **Imputed Interest Expense**

**CONTINGENT LIABILITIES**  
**SECTION 338(h)(10)**

**Results under the Current Section 338 Regulations**

**SELLER'S MADSP**

$$\text{MADSP} = \text{G} + \text{L} + \text{X}$$

- **Initially Include Only Fixed and Determinable Liabilities of Old T**
- **Recompute MADSP When Liability is Fixed**
- **Offsetting Deduction**
- **Other Treatment**

**BUYER'S BASIS**

- **Use AGUB Formula**
- **Include Bona Fide Liabilities of Old T**
- **Exclude Contingent Liabilities Until Fixed**
- **Other Treatment**



**CONTINGENT LIABILITIES**  
**SECTION 338(h)(10) CONTINUED**

**Result under the Proposed Section 338 Regulations**

**SELLER'S ADSP**

$$\text{ADSP} = \text{G} + \text{L}$$

- **Proposed regulations eliminate the “Fixed and Determinable” standard for determining the Liabilities of Old T.**
- **General principles of tax law apply in determining the timing and the amount of liabilities to be included in ADSP.**
- **ADSP is redetermined at such time and in such amount as an increase or decrease would be required, under general principles of tax law, for the elements of ADSP.**

**BUYER'S BASIS**

- **Use AGUB Formula**
- **Proposed regulations eliminate the “Fixed and Determinable” standard.**
- **In order to be taken into account for AGUB, a liability must be a liability of T that is properly taken into account in basis under general principles of tax law.**

## Contingent Liabilities

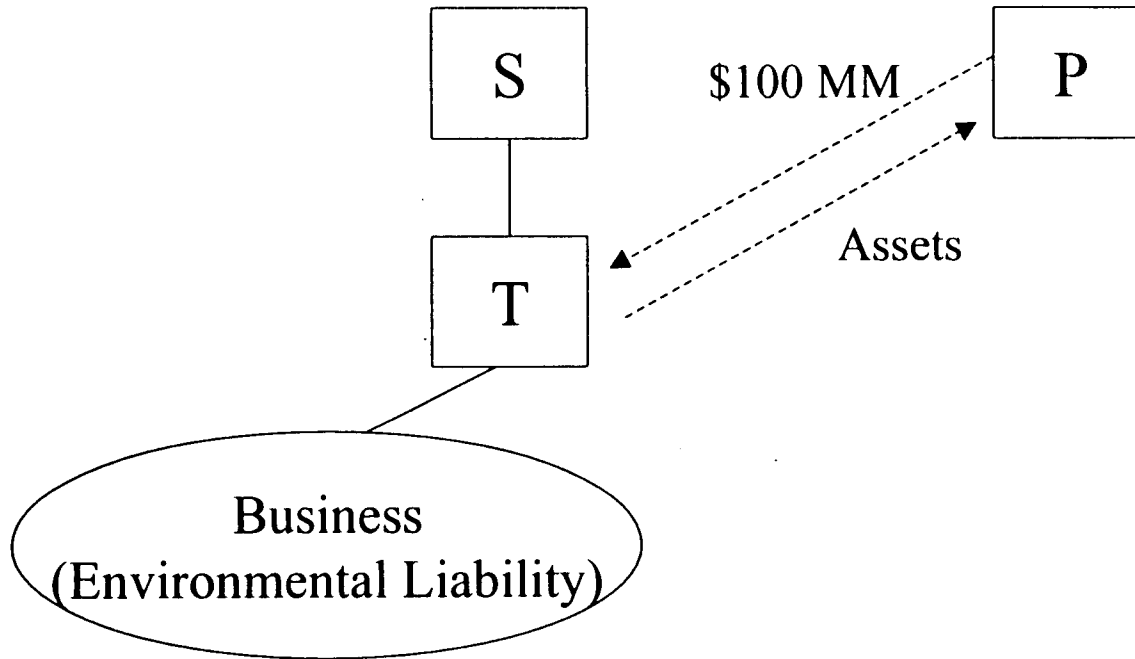

### **Facts**

S Corporation owns all the stock of T Corporation, which engages in Business. In year one, T sells its assets to P for \$100 million cash. As part of the transaction, S agrees to indemnify P against up to \$5 million of certain environmental liabilities arising out of T's past activities, subject to specified conditions. At the time, T's total environmental liabilities are estimated at \$10 million. In year five, \$3 million of these liabilities become fixed; P pays the \$3 million liability, and T (still a subsidiary of S) pays \$2 million to P as a settlement of the indemnity claim.

### **Questions**

1. What is the tax treatment of these transactions to S, T and P?
2. Would the tax treatment be different if S sold the T stock to P with a section 338(h)(10) election? Without a section 338(h)(10) election?

# Prop. Treas. Reg. §1.1032-3

## Property Acquisition -- Basic Example

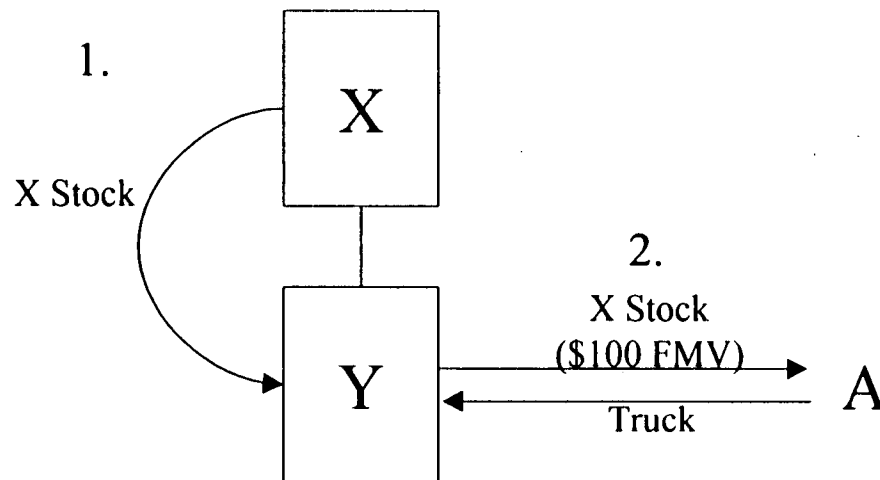

**Facts:** X owns all the stock of Y. Y agrees to acquire a truck from individual A for 10 shares of X stock with a FMV of \$100. X transfers to Y the X stock, Y immediately transfers the X stock to A to acquire the truck.

### Questions:

- What are the results?
- What if Y1, a wholly owned subsidiary of Y, agreed to purchase the truck using X stock?

### Reference:

Prop. Treas. Reg. §1.1032-3, Ex. 1.

## Prop. Treas. Reg. §1.1032-3

### Property Acquisition -- Basic Example with Options

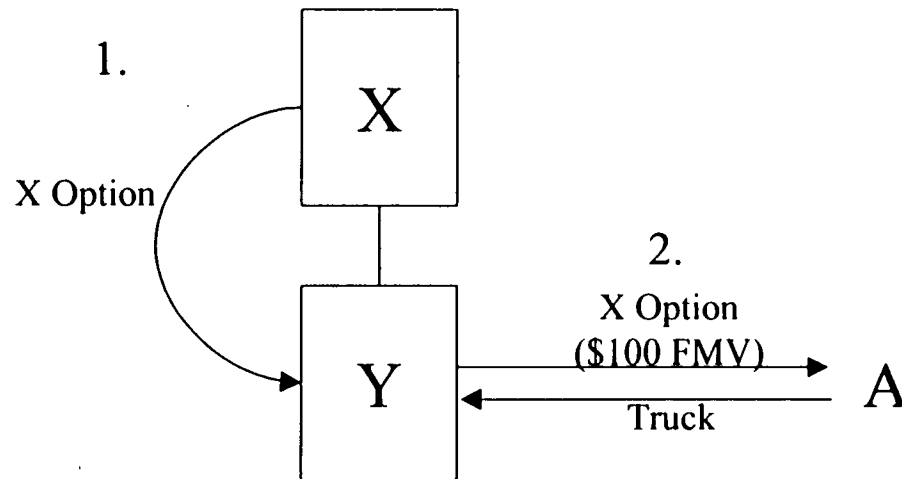

**Facts:** Same facts as in previous example, except that, rather than X stock, X transfers an option to buy X stock (FMV \$100).

#### Question:

•What are the results?

#### Reference:

Prop. Treas. Reg. §1.1032-3, Ex. 2.

# Prop. Treas. Reg. §1.1032-3

## Employee Compensation -- Basic Example

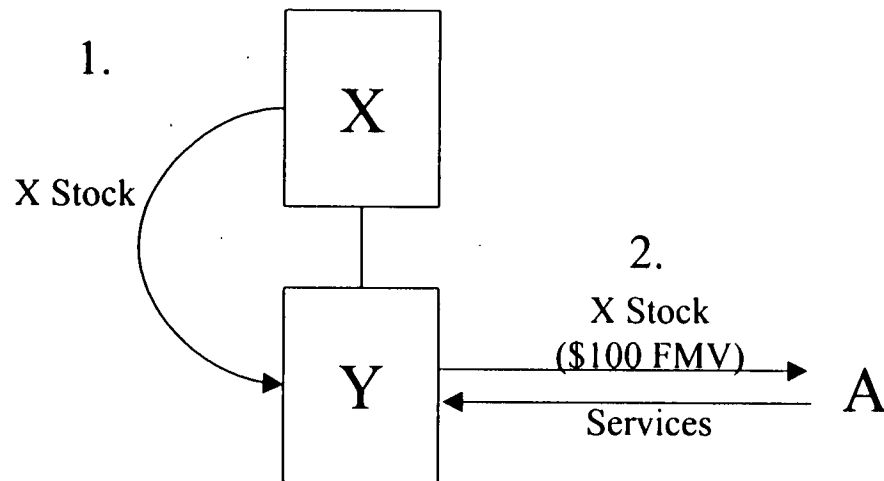

**Facts:** X owns all the stock of Y. Individual A is an employee of Y. Y agrees to transfer 10 shares of X stock to A as compensation. X transfers to Y the X stock, Y immediately transfers the X stock to A.

### Questions:

- What are the results?
- Would the result be different if X transferred the stock directly to A?

### References:

Prop. Treas. Reg. §1.1032-3, Ex. 3, Section 83(h) and Treas. Reg. §1.83-6(a) and (d).

## Prop. Treas. Reg. §1.1032-3

# Employee Compensation -- Reversionary Interest

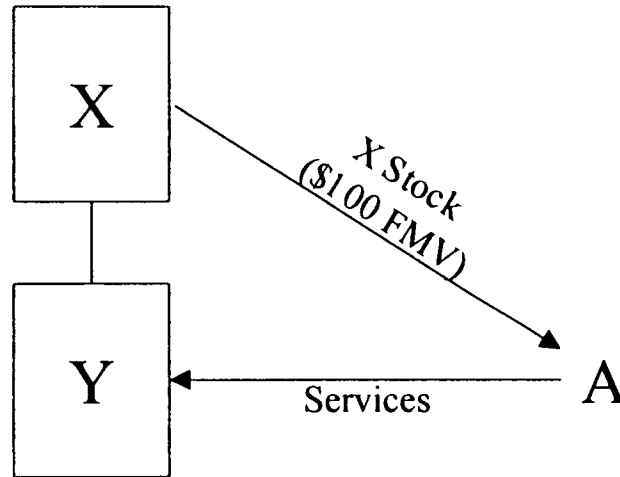

**Facts:** X owns all the stock of Y. Individual A is an employee of Y. X issues 10 shares of X stock subject to a substantial risk of forfeiture to compensate A for services. A does not have an election under section 83(b) with respect to the stock. X retains a reversionary interest in the X stock in the event that A forfeits the right to the stock. At the time the stock vests, the 10 shares of X stock have a FMV of \$100.

### Questions:

- What are the results?
- Would the result be different if Y (rather than X) retained the reversionary interest?

### References:

Prop. Treas. Reg. §1.1032-3, Exs. 4 & 5, Section 83(h) and Treas. Reg. §1.83-6(b), (d).

## Section 1032

### Contribution by X to Partnership -- TAM 9822002

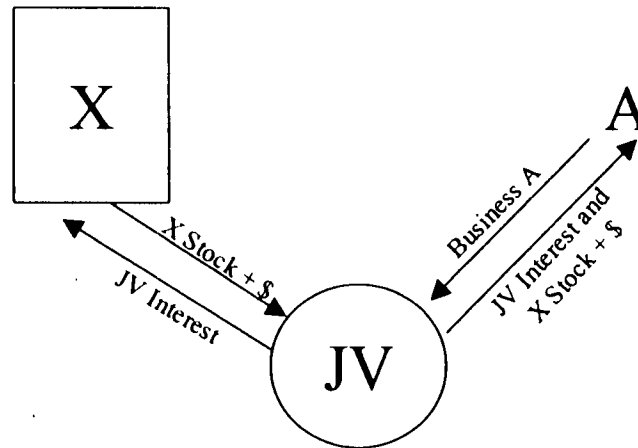

**Facts:** Corporation X and individual P form a partnership (JV). X contributes X stock and cash to JV for a JV partnership interest. P contributes Business A to JV for a JV partnership interest and the X stock and cash contributed by X.

#### Questions:

- The transaction will be characterized as a sale of Business A from P to JV under the disguised sale regulations.
- For purpose of section 1032, is the partnership treated as an aggregate of its members or as a separate entity? What are the results of this transaction?

#### References:

TAM 9822002; PLR 9822012; Treas. Reg. §1.707-3(a), Section 704(c).

## Section 1032

# The Immediacy Requirement -- TAM 199901003

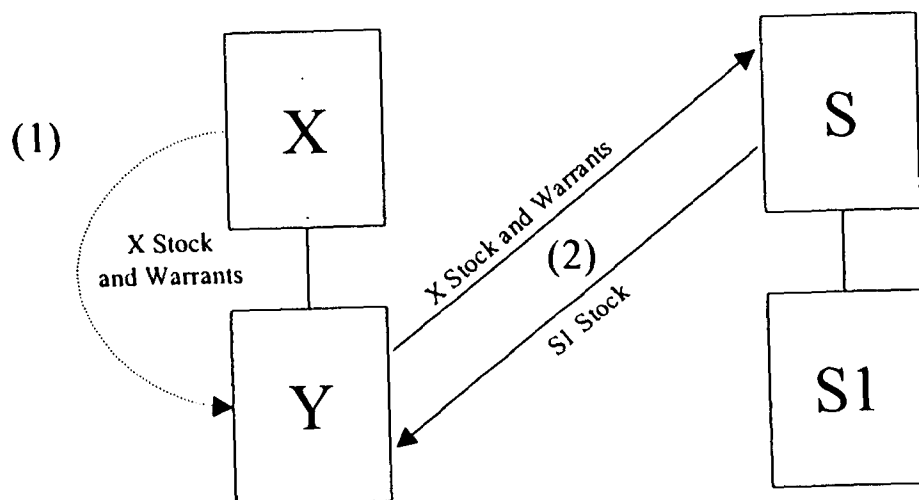

**Facts:** The following transaction took place before the issuance of Prop. Treas. Reg. §1.1032-3. X owned all the stock of Y. X entered into a purchase agreement with S. Under the agreement, Y agreed to purchase the S1 stock from S for X stock and warrants. The transaction was structured so that Y purchased the X stock and warrants to be used in the transaction from X in exchange for a Y note. X transferred the X stock and warrants to Y in exchange for the Y note and Y immediately transferred the same stock and warrants to S in exchange for the S1 stock. The Service ignored the sale of the X stock and warrants for the Y note and treated Y as having received the X stock and warrants as a capital contribution.

**Conclusion:** Y does not recognize gain on the disposition of the X stock and warrants. No zero basis result where X stock is transferred to Y pursuant to a plan in which the Y immediately disposes of the X stock. Quick turnaround of X shares meant that there was no opportunity for selective loss recognition. 50



## Section 1032

# The Immediacy Requirement -- TAM 199901003

## Continued

Comments: The TAM was issued one day before the issuance of Prop. Treas. Reg. §1.1032-3, the acquiring corporation must immediately transfer the stock of the issuing corporation. Although the TAM indicates that the fact that Y immediately disposed of the X stock be disposed of immediately. There is no explanation of what the result would be if Y did not immediately dispose of the X stock. It could be presumed that the Service would not rule favorably on such a transaction, but there does not appear to be any legal basis for this distinction. Query whether a taxpayer who failed the immediacy requirement of the proposed regulations could rely on this TAM instead?

References:

See TAM 199901003; Rev. Rul. 74-503; Rev. Rul. '80-76; Prop. Treas. Reg. §1.1032-3.

## 351(g) APPRECIATED PROPERTY

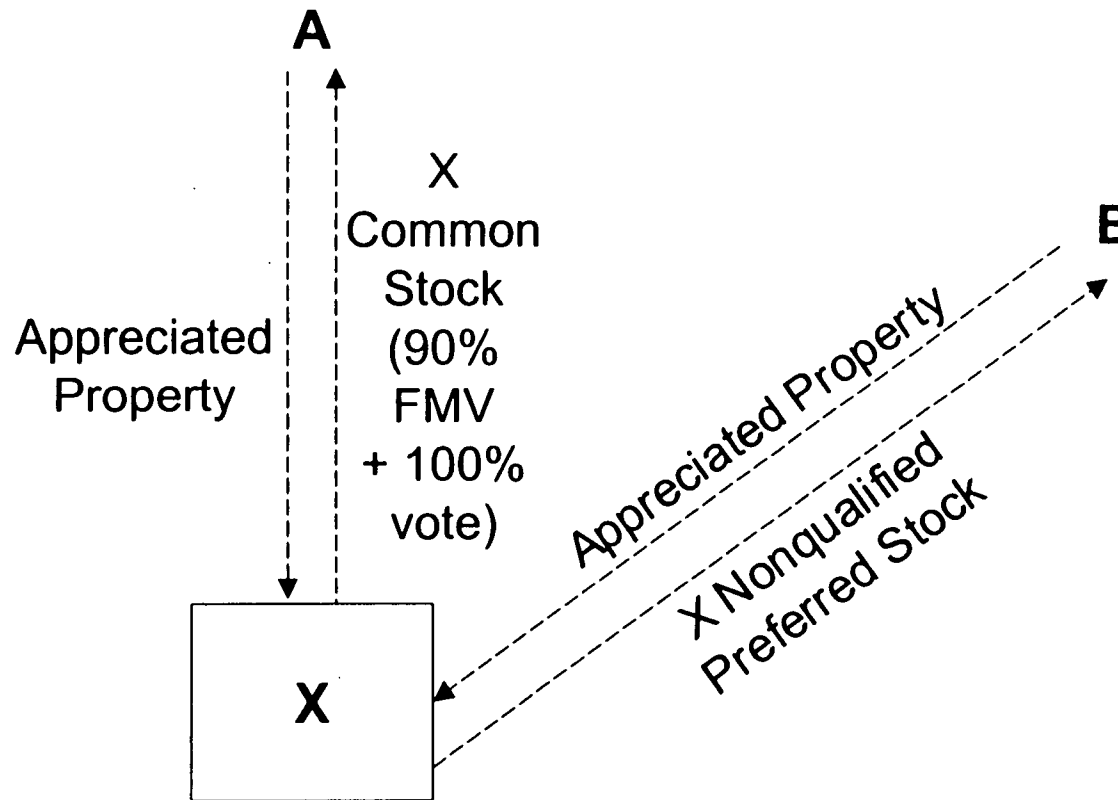

FACTS: A transfers appreciated property to Corporation X ("X") in exchange for common stock possessing 90% of the value and all of the voting power of X. B transfers appreciated property to X in exchange for "nonqualified preferred stock" within the meaning of section 351(g). What are the results of this transaction?

Are the results different if B receives the X preferred stock pursuant to a reorganization governed by section 368(a) or in an exchange otherwise governed by section 1036? 52

## 351(g) LOSS PROPERTY: NONQUALIFIED PREFERRED STOCK

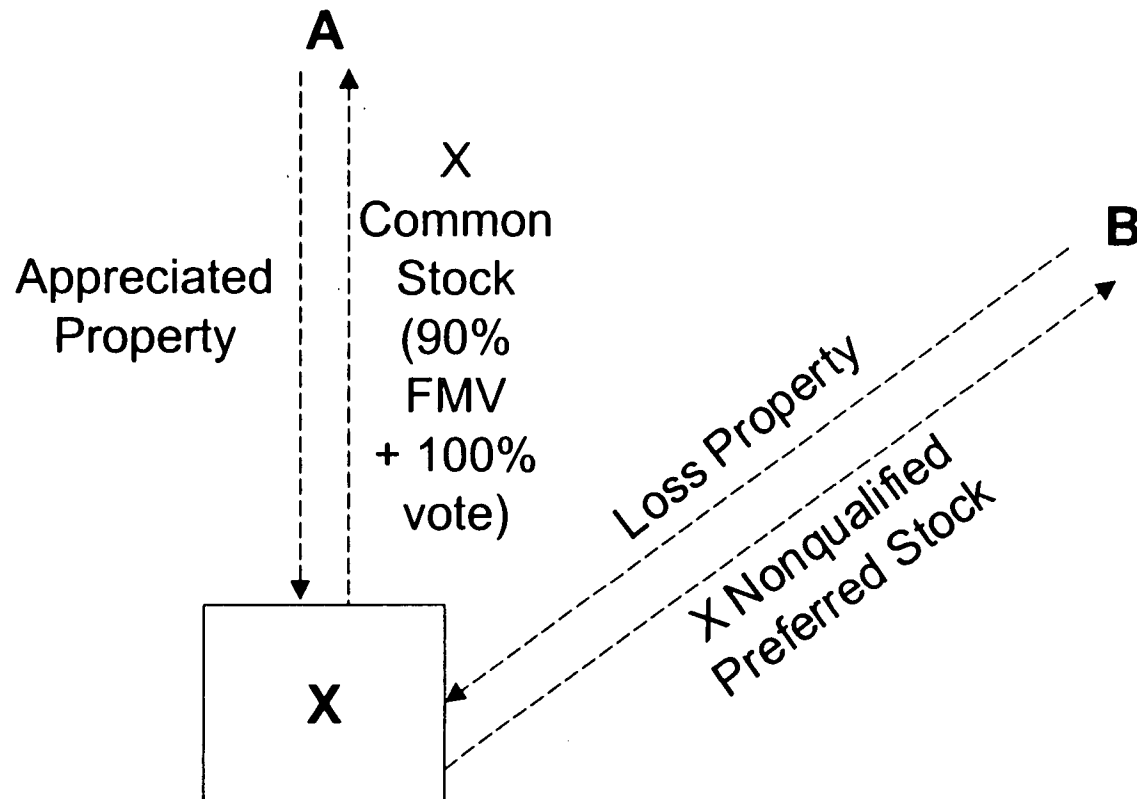

FACTS: What are the results if the facts are the same as in the previous example, except that the property that B contributes to X is loss property?

351(g) LOSS PROPERTY: NONQUALIFIED PREFERRED STOCK AND COMMON STOCK

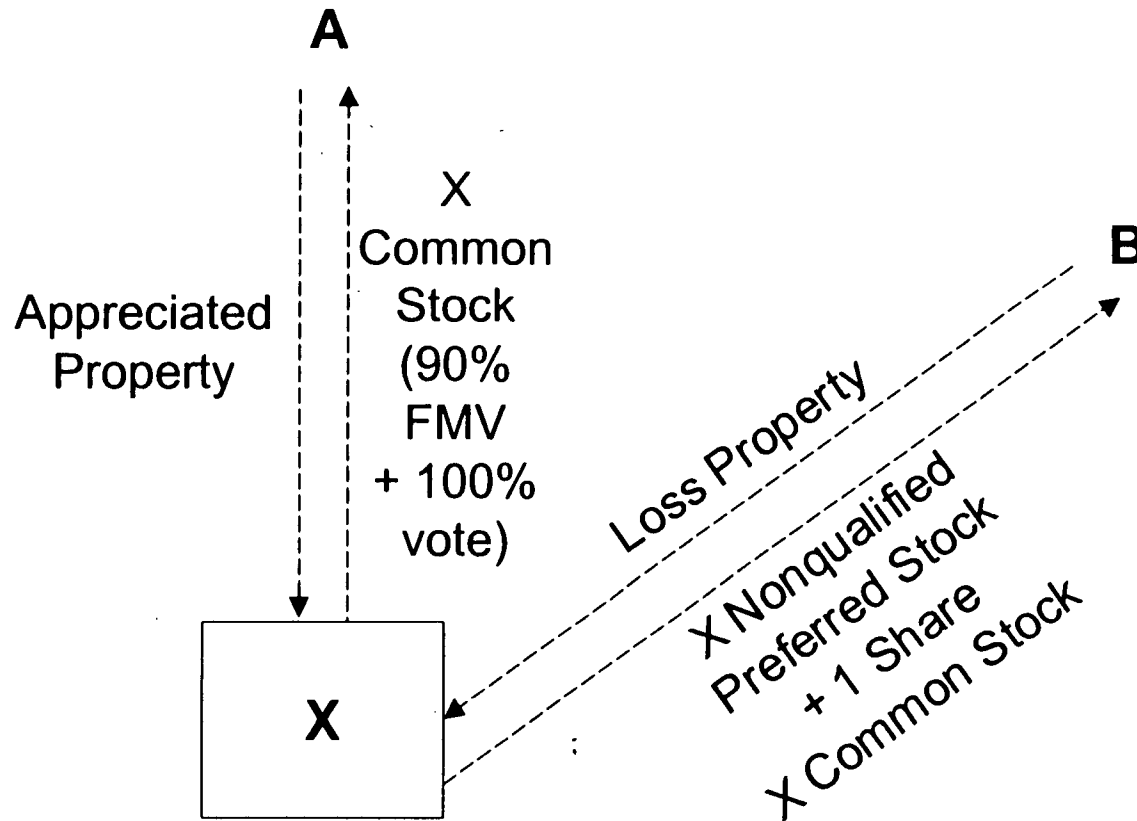

FACTS: What are the results if the facts are the same as in the previous example, except that, in addition to the nonqualified preferred stock, B receives one share of X common stock?

## B REORGANIZATION

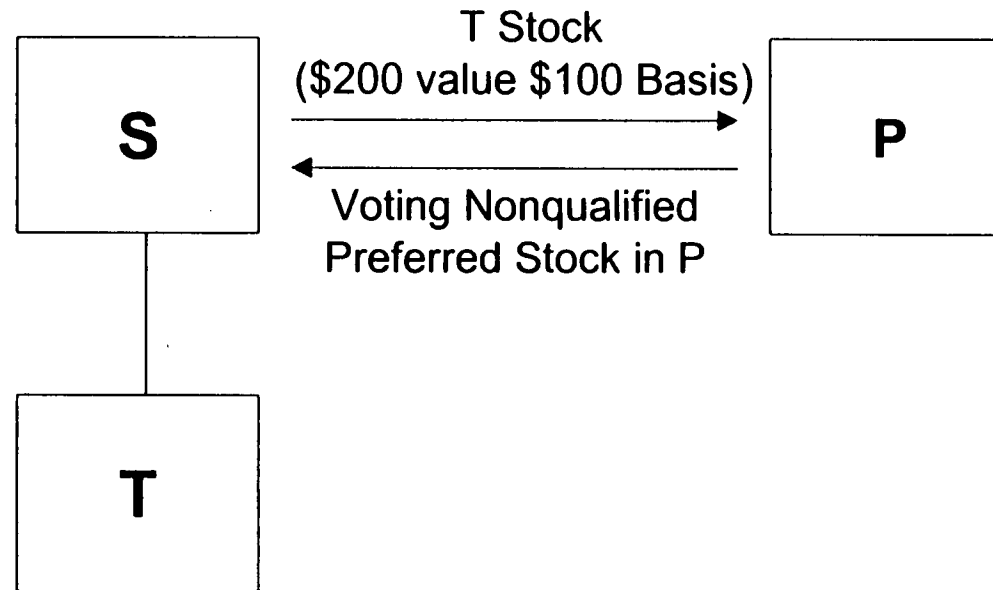

**FACTS:** P acquires all of the stock of T from S in exchange for P voting preferred stock, which constitutes nonqualified preferred stock within the meaning of section 351(g).

## DISQUALIFIED PREFERRED STOCK?

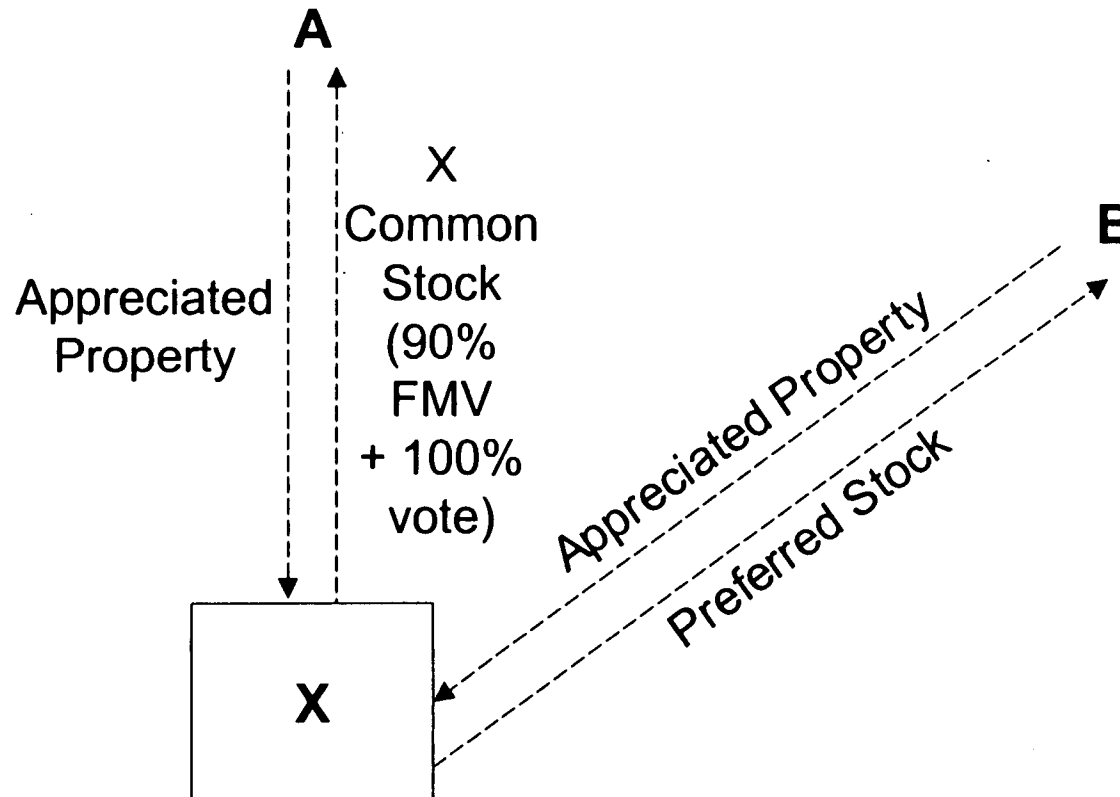

**FACTS:** What are the results if the facts are the same as in the first example, except that each share of preferred stock that B receives (i) has a built-in “put” right to the issuer exercisable after 10 years for \$10, (ii) a fixed dividend rate of 7% annually, (iii) a market value of \$10 and (iv) is convertible into one share of common stock which, on the closing date, has a value of \$9 per share?

## DISQUALIFIED PREFERRED STOCK?: ALTERNATIVE 1

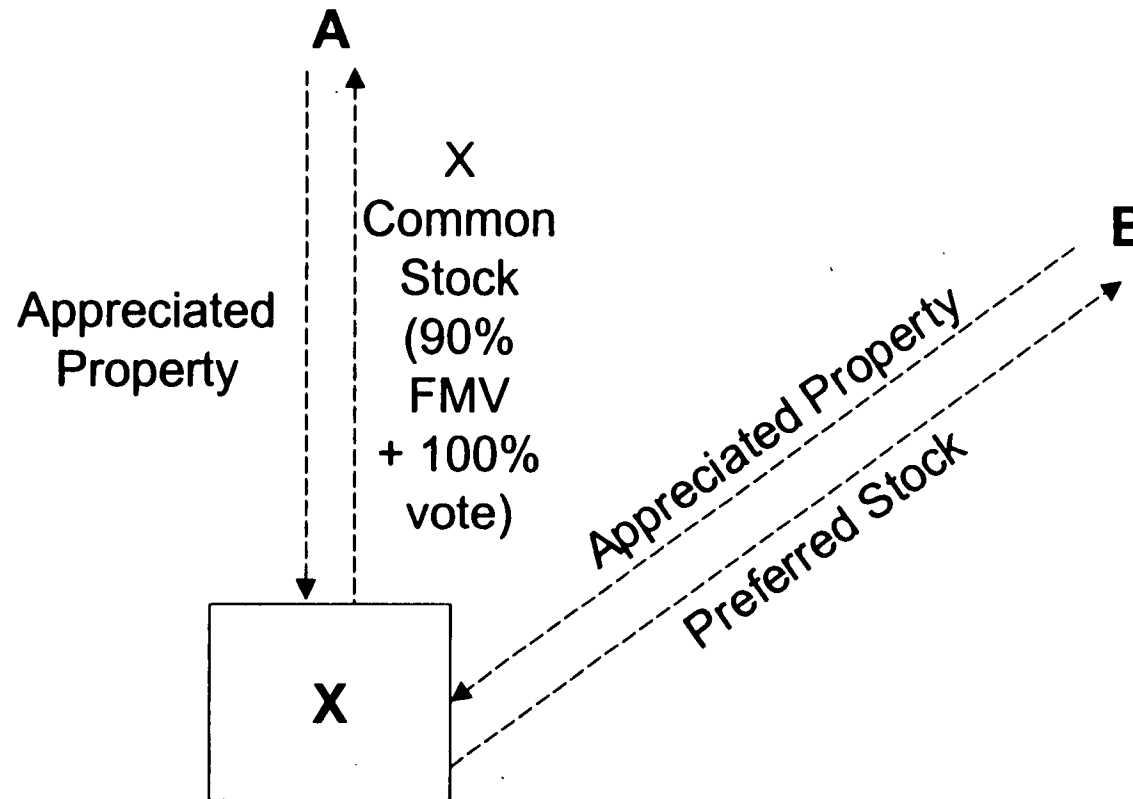

**FACTS:** What are the results if the facts are the same as in the previous example, except that (i) the X preferred stock is not convertible into X common stock, and (ii) the holder thereof is entitled to an additional dividend based upon a percentage of X's earnings in excess of a target amount?

## DISQUALIFIED PREFERRED STOCK?: ALTERNATIVE 2

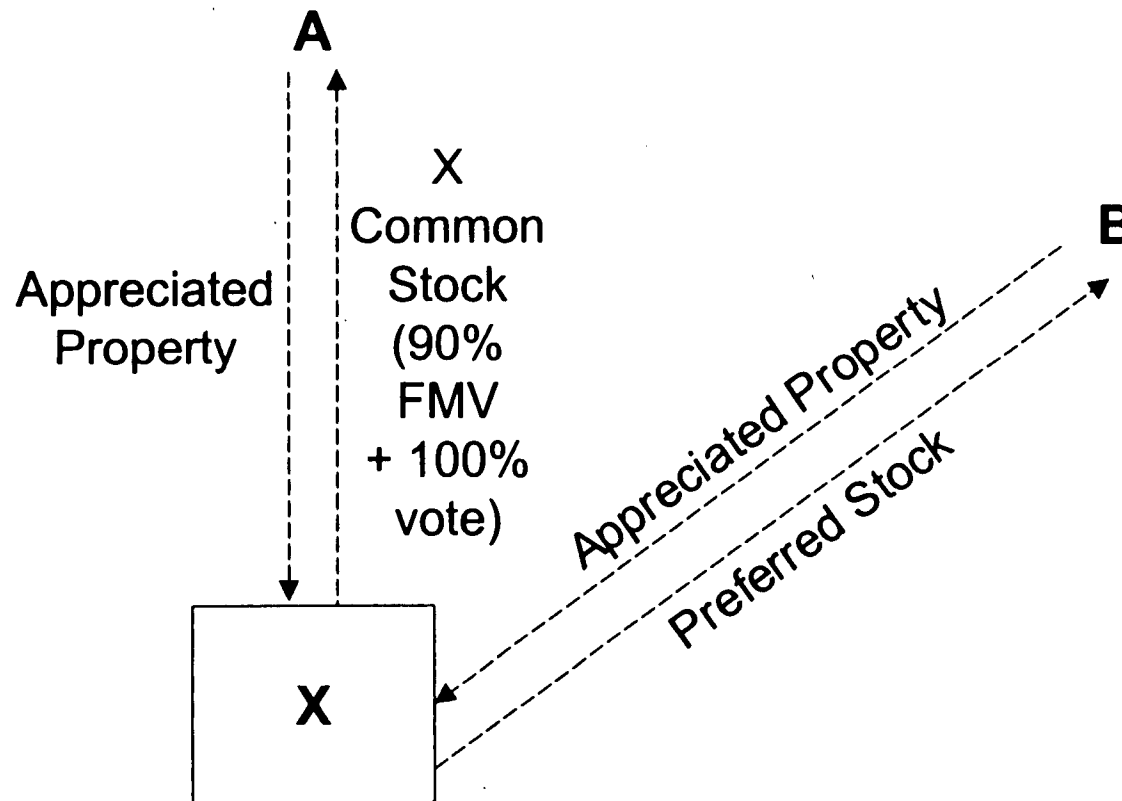

**FACTS:** What are the results if the facts are the same as in the previous example, except that each share of X preferred stock is entitled to dividends in any calendar year equal to the greater of 7% or the amount of dividends payable on a share of X common stock? Suppose the dividend rate is 14% rather than 7%?



# EXCHANGE OF STOCK FOR NONQUALIFIED PREFERRED STOCK

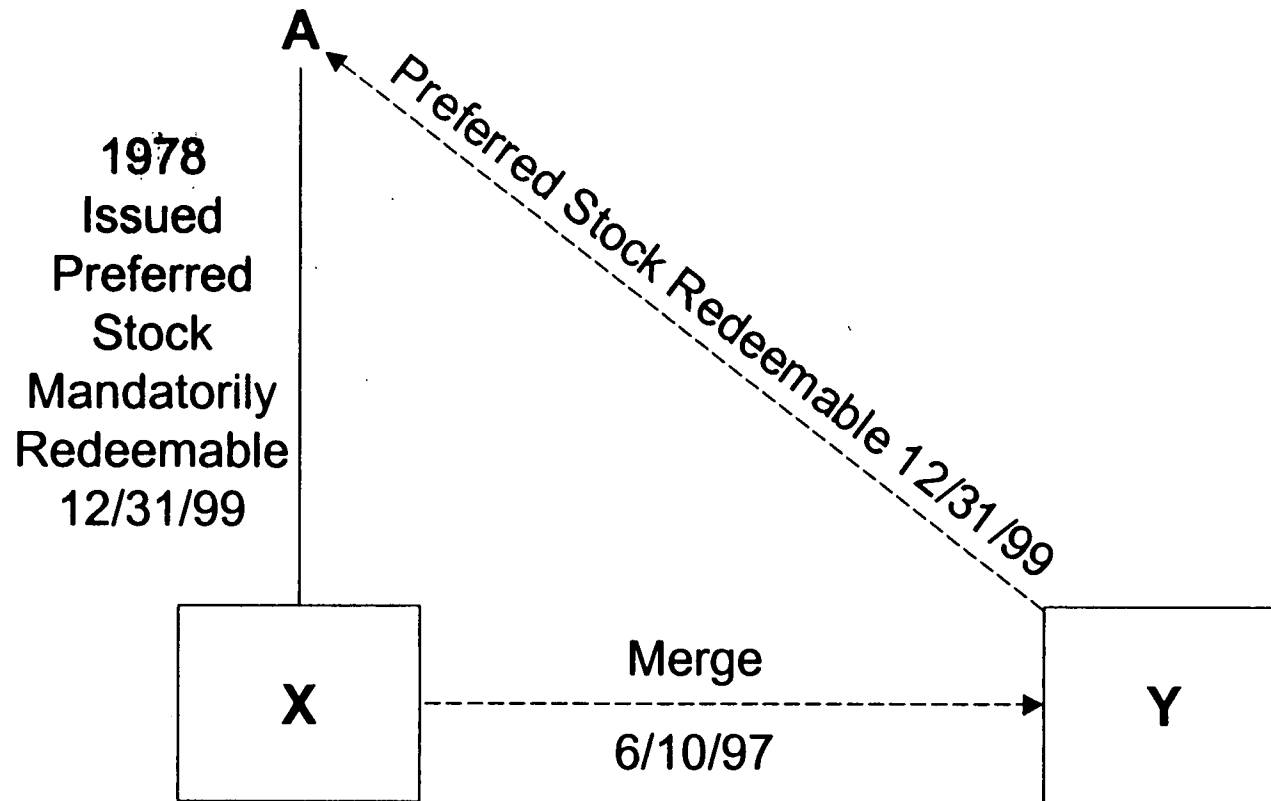

**FACTS:** Suppose that, in 1978, X issues to A stock that has a 5% fixed annual dividend rate, does not participate in corporate growth to any significant extent and is mandatorily redeemable on December 31, 1999. What are the results if, on June 10, 1997, X merges into Y and Y issues to A (in exchange for the X preferred stock described above) a new class of Y preferred stock having identical terms to those of the X preferred stock?

351(g): SECTION 304?

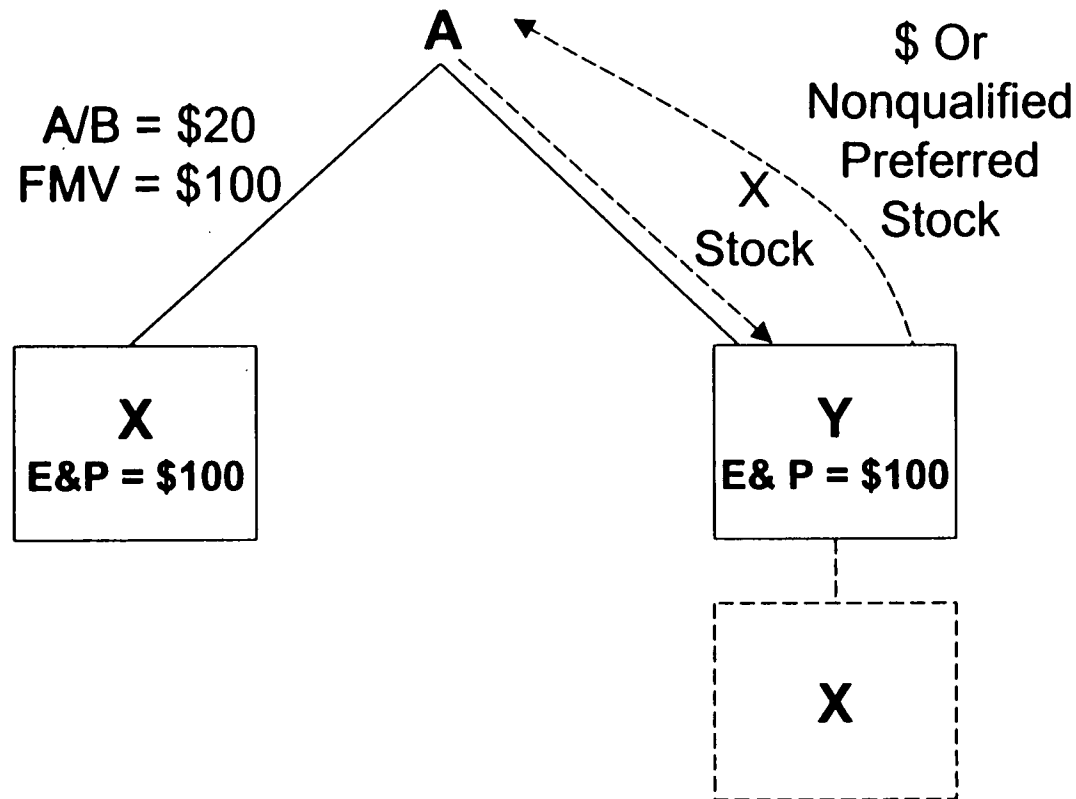

FACTS: Suppose that individual A owns (i) all of the stock of X (the stock has a basis of \$20 and a fair market value of \$100) and (ii) all of the stock of Corporation Y ("Y"). Assume that X and Y's aggregate earnings and profits are \$200. What are the results if A transfers all of the stock of X to Y in exchange for (a) \$100 cash or (b) nonqualified preferred stock of Y having a value of \$100? Do the results differ if A is a corporation rather than an individual? Does it matter whether A files a consolidated return with Y?

## Sections 357 and 358

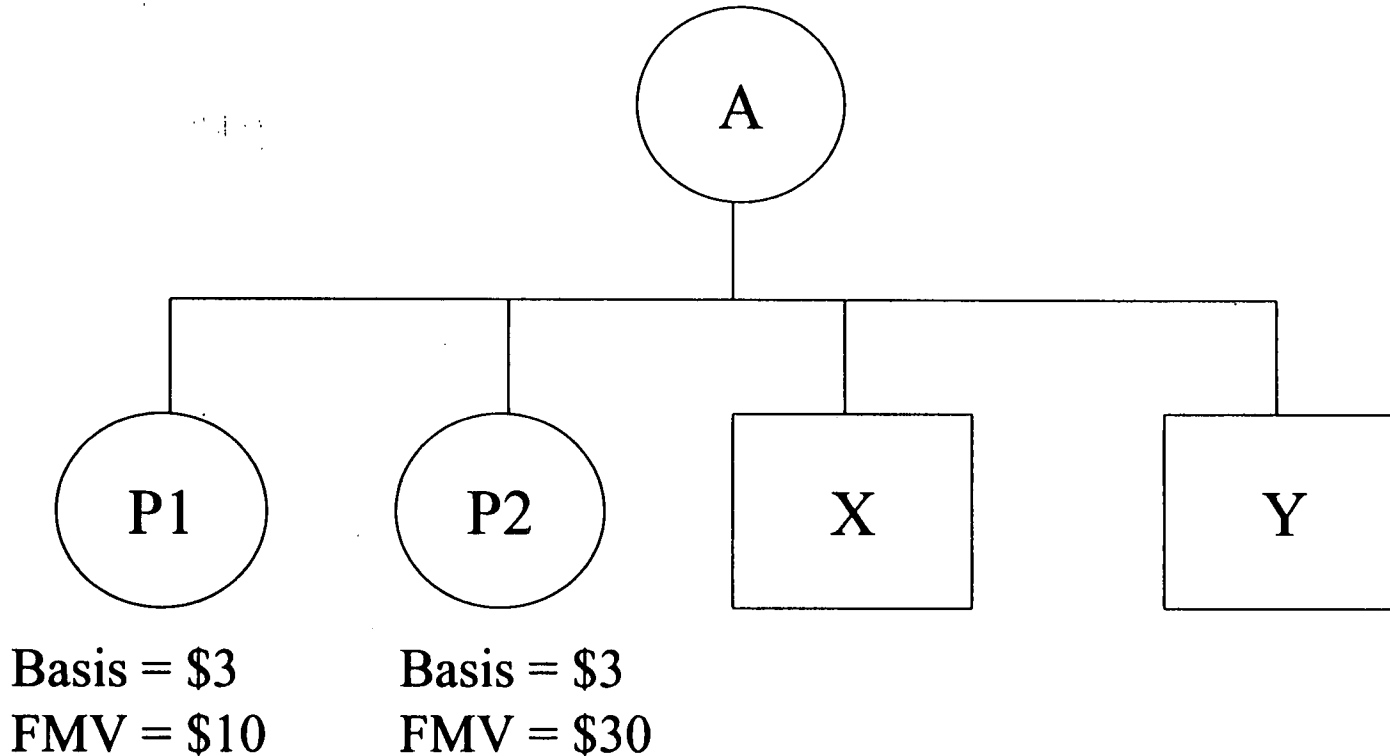

### **General Facts**

A owns Property P1 (fair market value of \$10 million, adjusted basis of \$3 million) and Property P2 (fair market value of \$30 million and adjusted basis of \$3 million). A is indebted to Bank B in the amount of \$5 million, and the debt is secured by P1 and P2.

A transfers P1 to Corporation X for X stock and, in some of the problems, A also transfers P2 to Corporation Y for y stock. These transfers qualify under section 351. 61

## Sections 357 and 358 Continued

### Questions

1. A transfers P1 to X. P1 remains subject to B's lien, but X makes no agreement to assume the liability. B does not release A from liability on the debt and is otherwise not a party.
2. A transfers P1 to X and P2 to Y. P1 and P2 both remain subject to B's lien, but neither X nor Y agrees to assume any liability.
3. The facts are the same as in 2., except that X agrees to assume the full liability.
4. The facts are the same as in 2., except that both X and Y agree to assume the full liability.
5. A's debt to B is nonrecourse and is in the amount of \$12 million. A transfers P1 to X. P1 remains subject to B's lien, but X makes no agreement to assume the liability.

Is the result different if A agrees to indemnify X for any payment made by X on the debt?

In either case, does it matter if A is a foreign person not subject to U.S. tax.

## Sections 357 and 358 Continued

6. A is a foreign person not subject to U.S. tax. A's debt to B is recourse and is in the amount of \$9 million. A transfers P1 to X. P1 remains subject to B's lien, and X agrees to assume the liability.

### **Authorities**

Code sections 357(d) and 358(d)

Introduction of H.R. 4852, Hon Bill Archer, 144 Cong. Rec. E2236, 105th Cong. 2d Sess. (October 19, 1998)

# Quantitative Continuity

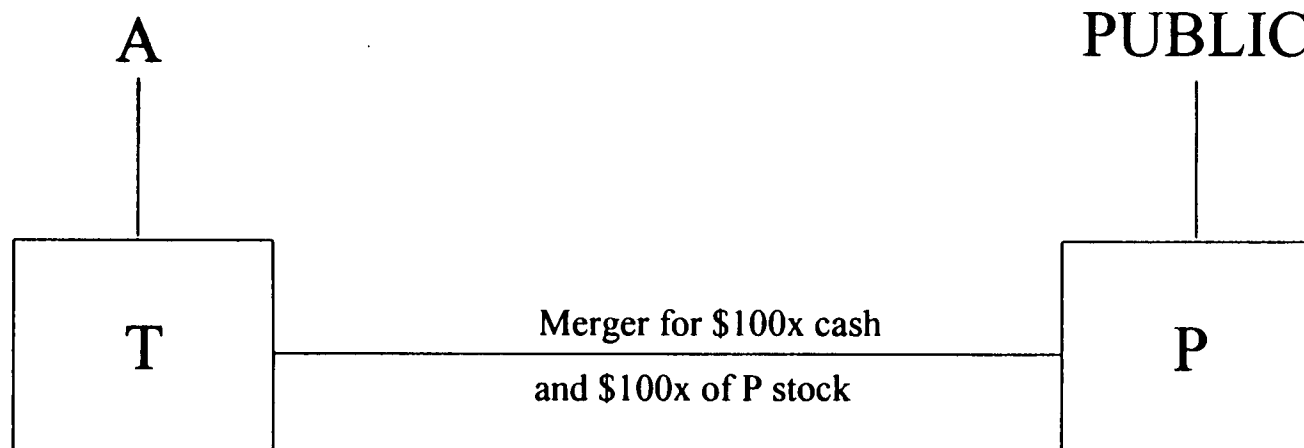

**Facts:** T, a corporation wholly-owned by individual A, enters into an agreement to merger into P, a publicly traded corporation, in exchange for \$100x and 100 shares of P stock at a time when P stock is trading at \$1x share.

# Changes in Price

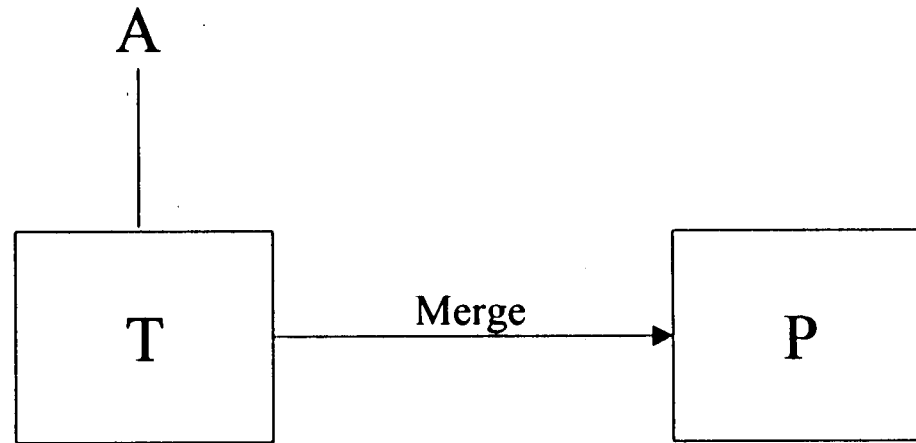

**Facts:** A owns all of the stock of T corporation. T enters into an agreement to merge into P. P will issue \$100 cash and 100 shares of its stock in the merger. At the time the contract is entered into, P's stock is trading at \$1 per share. At the time of closing -- six months later -- P's stock is trading at \$0.55 per share.

# Contingent Earn-out

## Closing

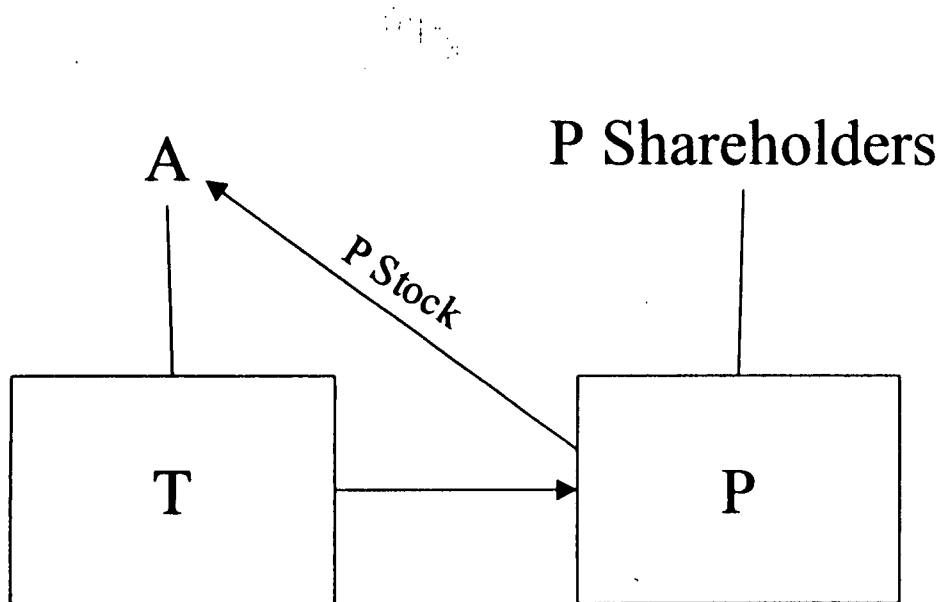

## Earn-out Date

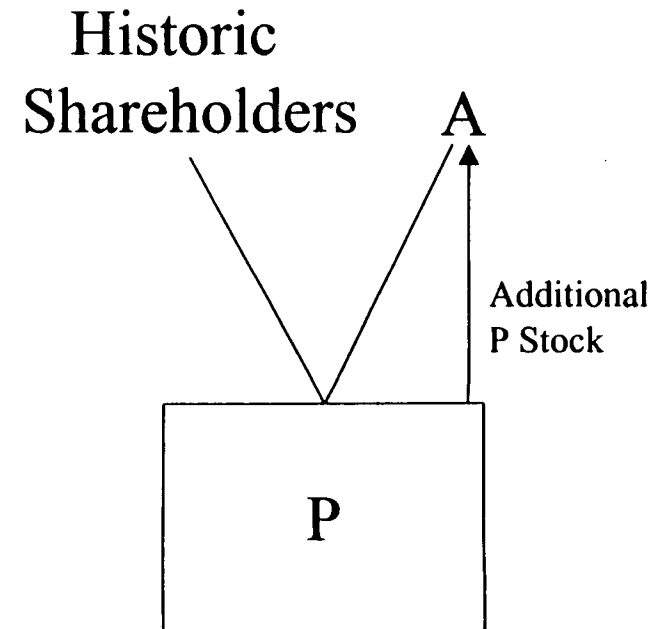

**Facts:** A owns all the stock of T corporation. P wishes to acquire T in a tax-free transaction. However, the parties are unable to agree on a value for T due to disputes regarding its likely future earnings. The parties agree that T will merge into P. P will issue \$50 million cash and \$50 million of its stock at closing. If the future earnings of P meet certain targets, P must pay an additional \$100 million on the third anniversary of the closing date (in the same 50/50 proportion).



# Contingent Earn-out (Continued)

1. Assume that, at closing, P's stock is trading at \$1 per share, and on the Earn-out date, P's stock is trading at \$5 per share.

2. <u>Closing</u>	<u>Earn-Out</u>	<u>Total</u>
\$50 cash	\$50 cash	\$100 cash
50shares x \$1 = \$50	10shares x \$5 = \$50	60shares =
		\$100 FMV

3. <u>Value of Stock:</u>	<u>Closing</u>	<u>Earn-Out</u>
	50shares x \$1 = \$50	50shares x \$1 = \$50
	10shares x \$1 = \$10	10shares x \$5 = \$50
	\$60	\$100

4. Continuity: If valued on Earn-out date:  $100/200 = 50\%$   
 If valued at closing:  $60/160 = 37.5\%$

# PLR 9838007 (June 16, 1998)

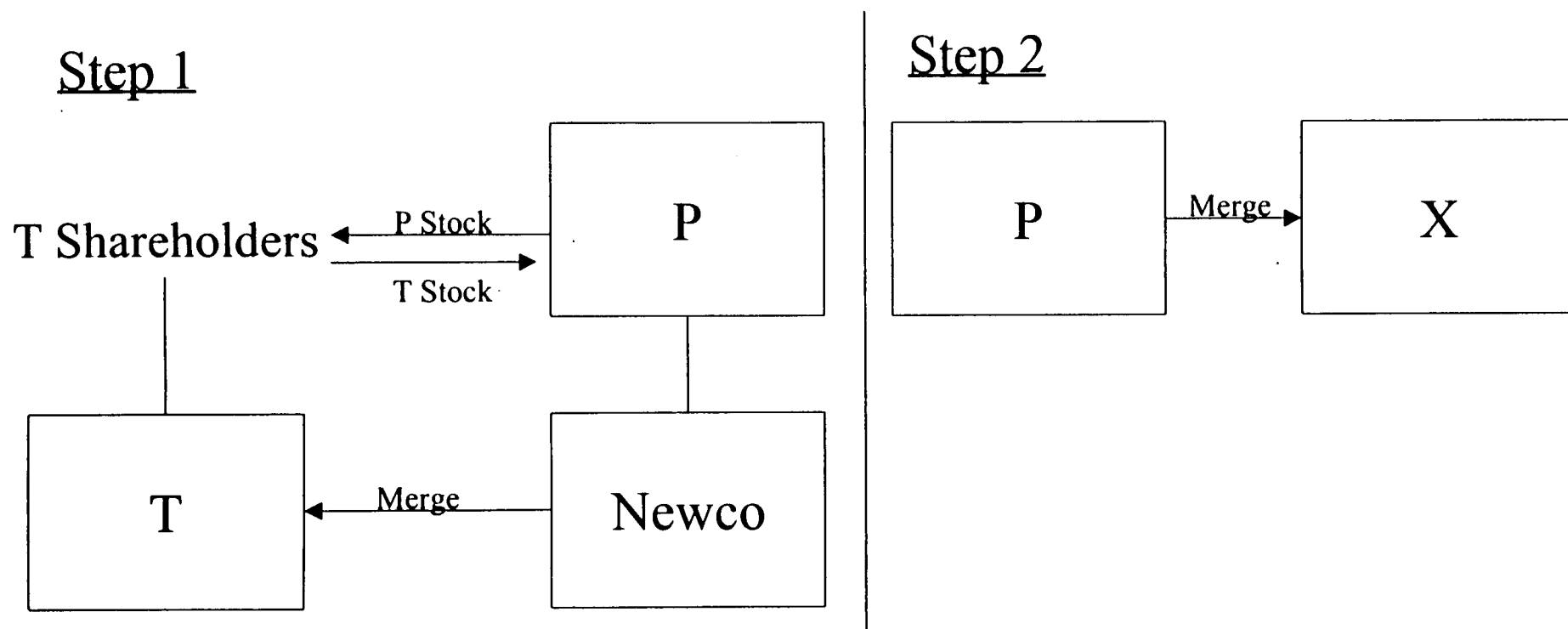

**Facts:** Newco merges into T in a reverse triangular merger under section 368(a)(2)(E), with T's shareholders receiving P stock at closing plus a right to receive additional P stock two years after closing in exchange for their T stock. Prior to the issuance of the additional P stock, P merges into X, an unrelated corporation. As a result of this merger, the former T shareholders receive X stock instead of P stock in satisfaction of their right to receive additional P stock in the reverse triangular merger.

# Post-Reorganization Continuity

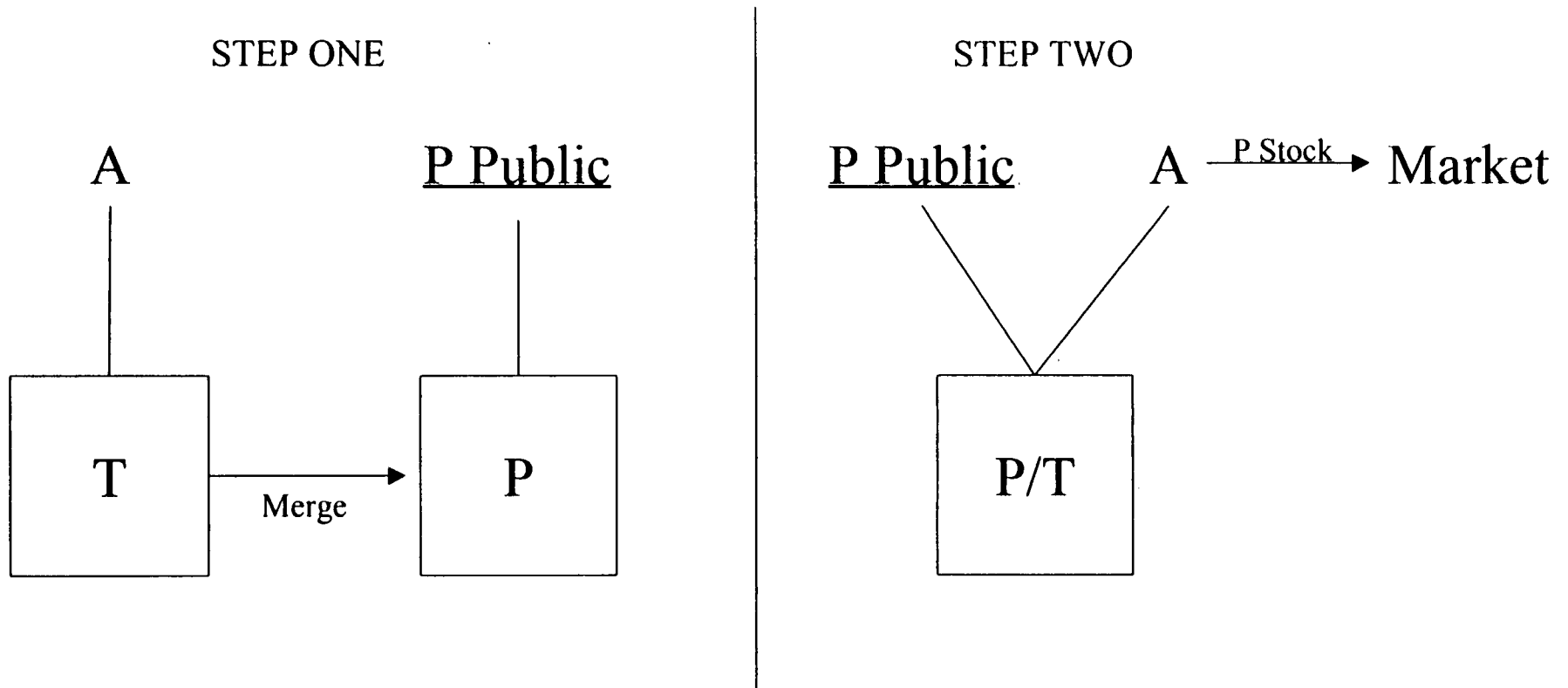

Facts: A owns all of the stock of T Corporation. A and P agree that T will be merged into P in a transaction intended to qualify as a reorganization under section 368(a)(1)(A).

Subsequent to the merger, A sells all of its P stock in the open market.

# Post-Reorganization Continuity: Redemption Transaction

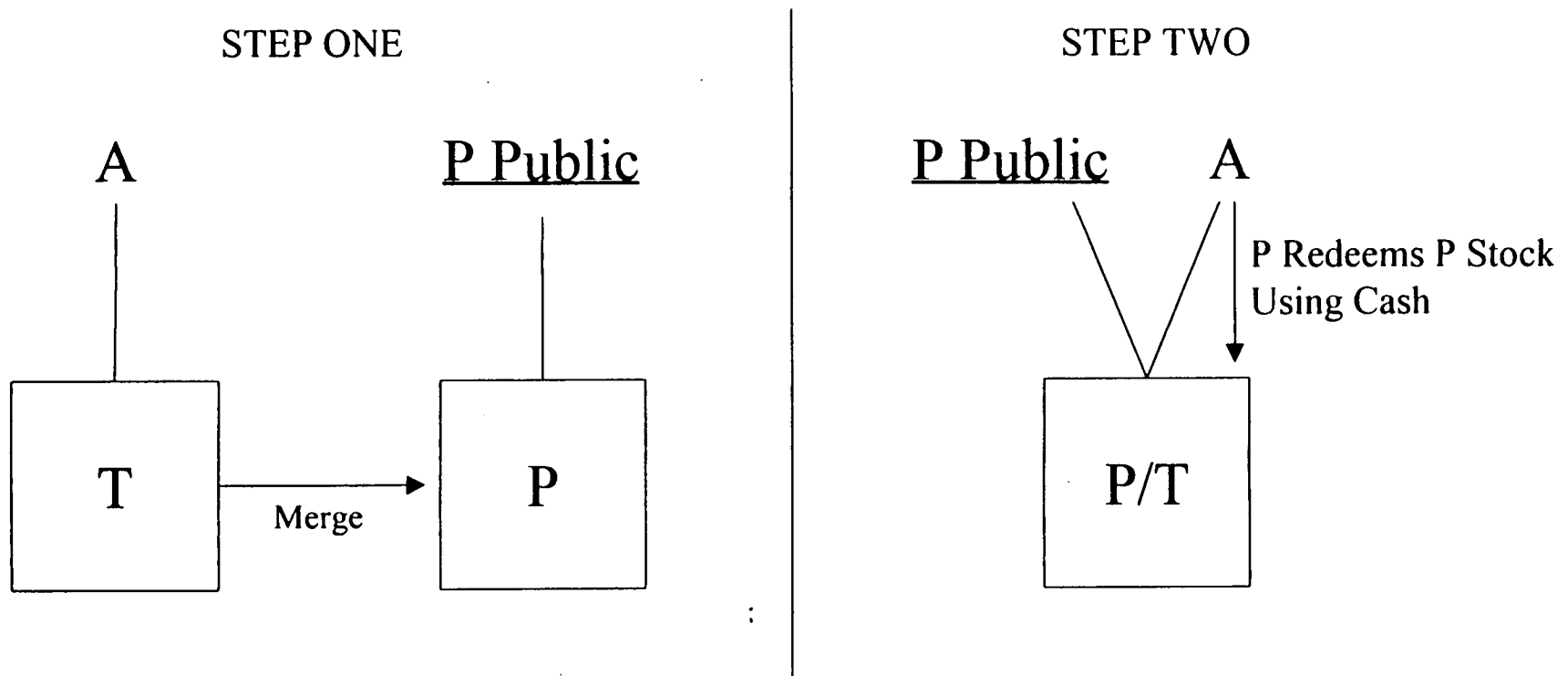

**Facts:** Assume that the facts are the same as in the previous example, except that A sells its P stock back to P rather than in the open market.

# Post-Reorganization Continuity: Public Market Buyback Program

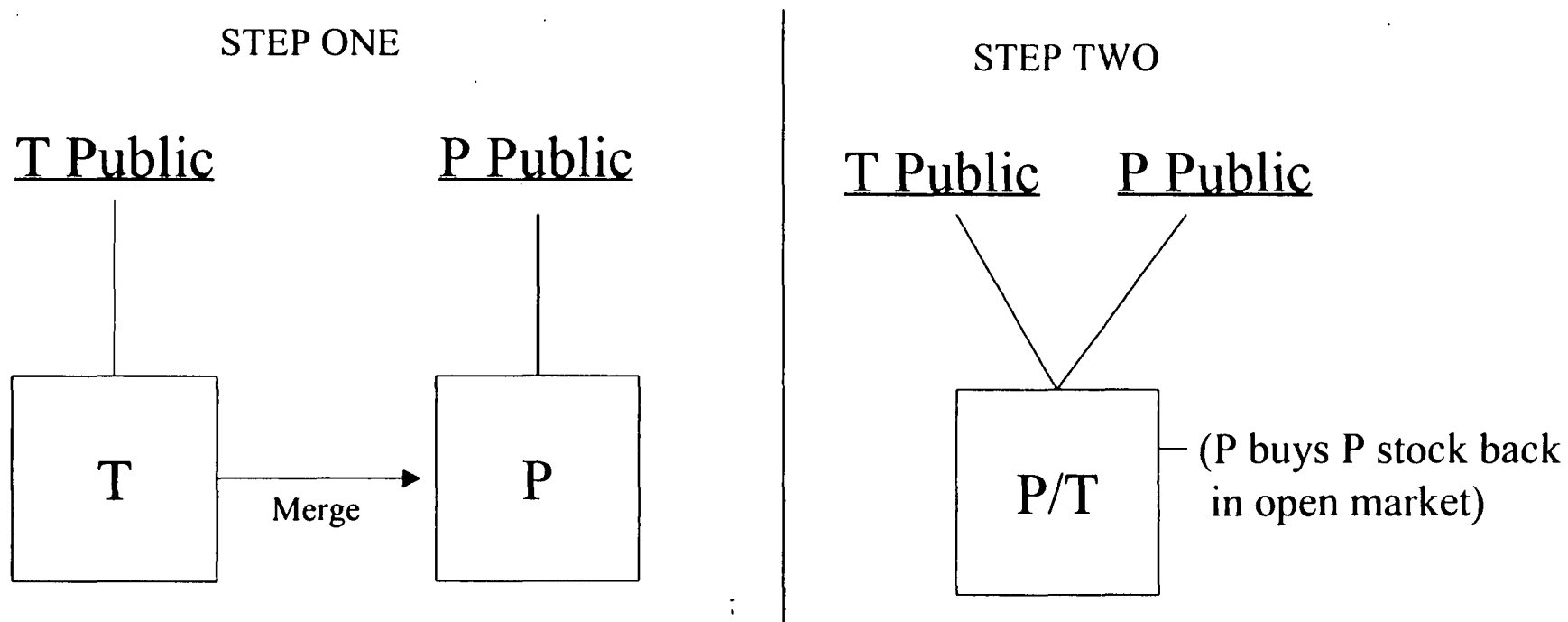

Facts: T merges into P, with the former T shareholders receiving 10% of P's outstanding stock. Immediately after the merger, P repurchases a small percentage of its stock in the open market as part of an ongoing stock repurchase program.

# PLR 199935042

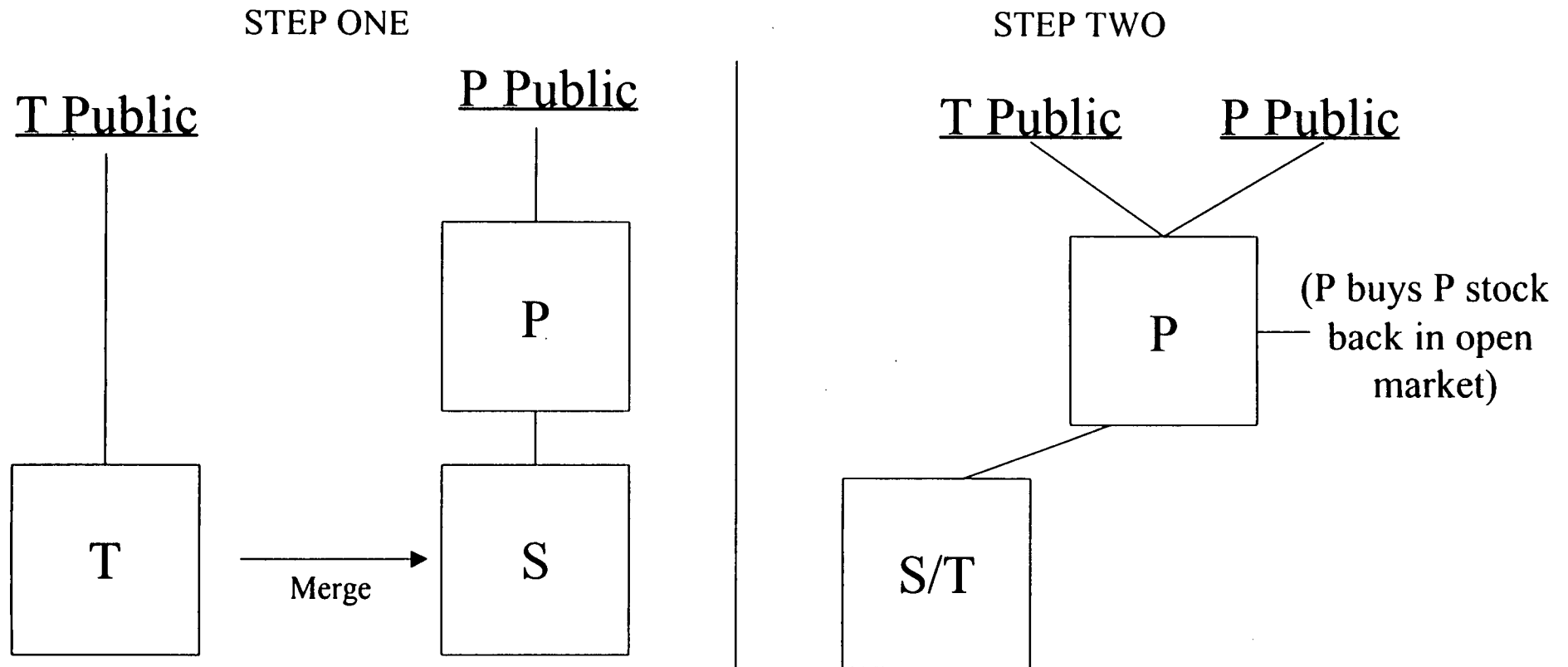

**Facts:** T merges into S, with the former T shareholders receiving P common stock or cash. At least 55% of the total merger consideration will be P common stock. The relative value of T in comparison to the value of P is less than 10%. Prior to the date of the merger agreement the P board of directors approved a stock repurchase plan. The repurchase plan was intended to help P offset dilution as a result of stock issuances under its employee stock option and employee stock purchase plans as well as to permit P to repurchase P common stock if it deemed such purchases (continued)

# PLR 199935042 Continued

## Facts (continued)

to be in the best interests of its stockholders.

At the time the merger agreement was executed, P's Board of directors amended the repurchase plan by increasing the amount of stock P may repurchase in the open market. This increase was intended to help P offset dilution caused by the issuance of common stock in the merger.

P did not make any repurchases, pursuant to the repurchase plan, prior to entering into the merger agreement, but has repurchased shares in the open market since entering into the merger agreement. P expects to make additional repurchases of its common stock pursuant to the repurchase plan after the consummation of the merger.

## Question

Will P's purchase of its common stock following the merger pursuant to the repurchase plan cause the merger to fail the continuity of interest requirement?

# Buyback Issues (Alternatives)

1. What is a “small” percentage, as described in Treas. Reg. 1.368-1(e)(6), Ex.8? Is 10% a small percentage? 30%?
2. What if the stock repurchase program is created or modified in connection with P’s acquisition of T?
3. What if P issued 75% of its stock to T in the merger, and then P repurchased 70% of its stock in the open market?
4. What if P’s acquisition of T were a reorganization under section 368(a)(1)(B) or section 368(a)(2)(E)?
5. If the buyback is “in connection with” the reorganization, how is the portion of P stock acquired from former shareholders of T determined?



# Examples Regarding Stock Buybacks

For purposes of the following examples, (i) P is the issuing corporation, whose stock is widely held and publicly traded, (ii) T is the target corporation, (iii) S is a wholly owned subsidiary of P, and (iv) all corporations have only one class of stock outstanding.

## Example 1

T merges into P, and the former T shareholders receive 10 percent of P's outstanding stock. Immediately after the merger, P repurchases a small percentage of its stock in the open market as part of its ongoing stock repurchase program. The repurchase program was not created or modified in connection with P's acquisition of T. What is the impact of the repurchase on the merger, assuming the merger otherwise qualifies as a reorganization under section 368(a)(1)(A)? See Treas. Reg. § 1.368-1(e)(6), example 8.

## Example 2

Suppose the facts are the same as described in example 1, except that, immediately after the merger, P repurchases 10 percent of its stock in the open market. Is 10 percent a small amount? Does it matter? Suppose P repurchases 30 percent of its stock immediately after the merger?

# Examples Regarding Stock Buybacks - Continued

## Example 3

Suppose the facts are the same as described in (a) example 1 or (b) example 2, except that the stock repurchase program is created or modified in connection with P's acquisition of T. What is the impact of the repurchase program on the acquisition?

## Example 4

Suppose the facts are the same as described in example 1, except that P issues 75 percent of its stock to T in the merger and, immediately after the merger, P repurchases 70 percent of its stock in the open market.

## Example 5

Does it matter whether, in any of the examples above, P's acquisition of T is a potential reorganization under either section 368(a)(1)(B) or section 368(a)(2)(E), rather than section 368(a)(1)(A)?

# Maintaining Direct Or Indirect Interests In The Target Corporation

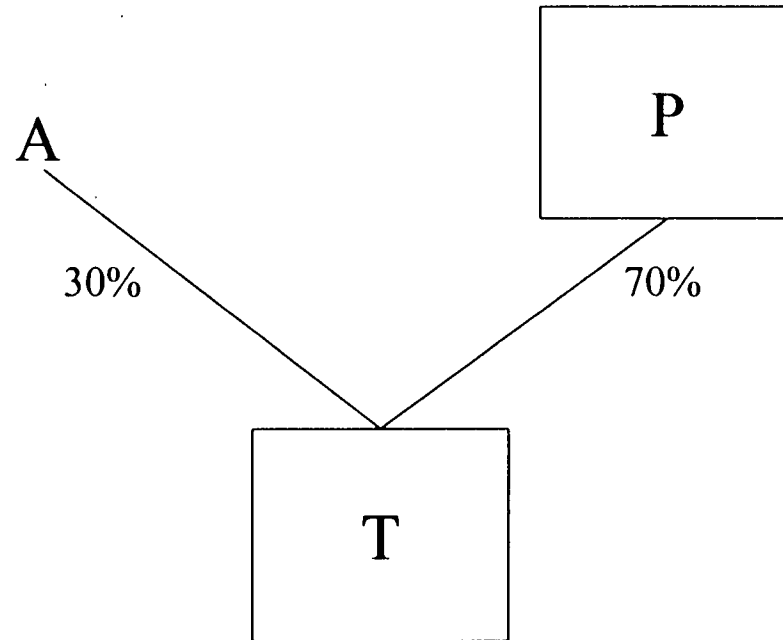

Facts: A owns 30% of the stock of T. P owns 70% of the stock of T. T merges into P, and A receives cash in the merger. P's 70% stock ownership was not acquired by P in connection with the acquisition of T's assets.

# Yoc Heating

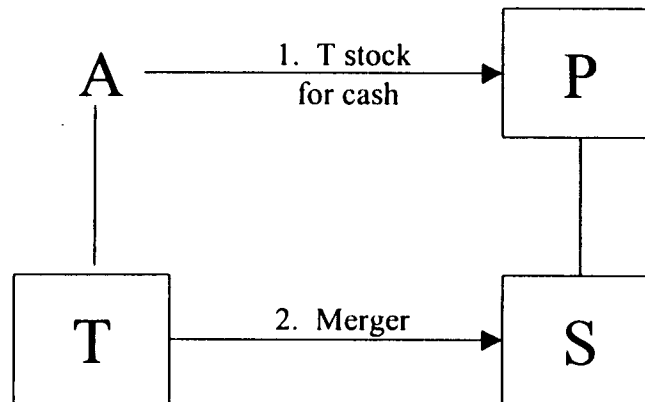

**Facts:** A owns all the stock of T. P owns all of the stock of S Corporation. P purchases A's T stock for cash. T then merges into S.

# Old Treas. Reg. § 1.368-1(e)(6),

## Example 2

1.

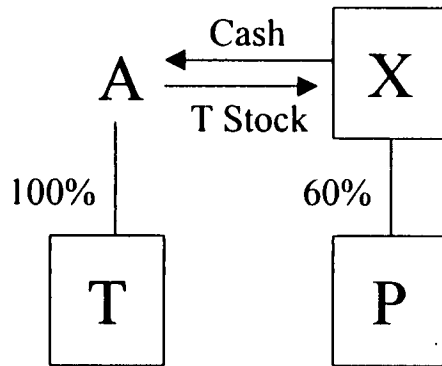

2.

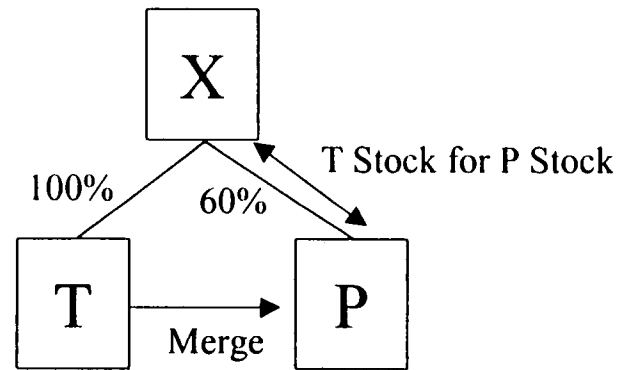

3.

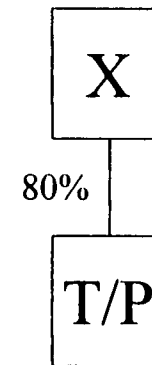

Facts: Corporation X owns 60 percent of the stock of P. A owns 100 percent of the stock of T. X buys A's T stock for cash. T then merges into P. In the merger, X exchanges all of its T stock for additional stock of P. As a result of the issuance of the additional stock to X in the merger, X's ownership interest in P increases from 60 to 80 percent of the stock of P.

# New Treas. Reg. § 1.368-1(e)(6),

## Example 2

1.

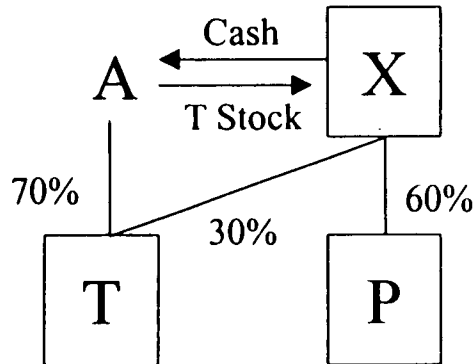

2.

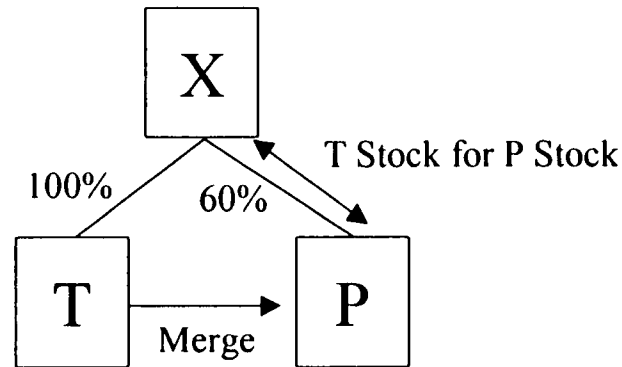

3.

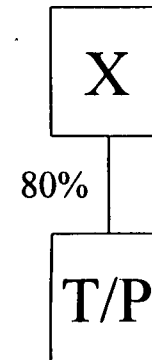

Facts: Corporation X owns 60 percent of the stock of P and 30 percent of the stock of T. A owns the remaining 70 percent of the stock of T. X buys A's T stock for cash in a transaction that is not a qualified stock purchase within the meaning of section 338. T then merges into P. In the merger, X exchanges all of its T stock for additional stock of P. As a result of the issuance of the additional stock to X in the merger, X's ownership interest in P increases from 60 to 80 percent of the stock of P.

# Pre-Reorganization Continuity And Redemption Transactions

STEP 1-A

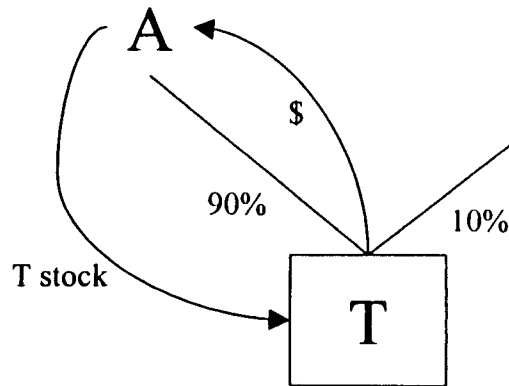

STEP 1-B

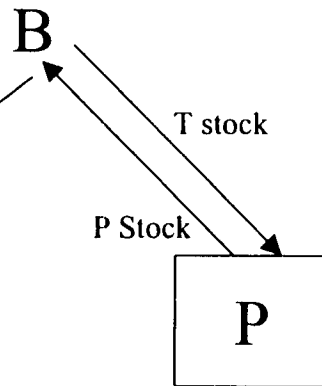

STEP 2

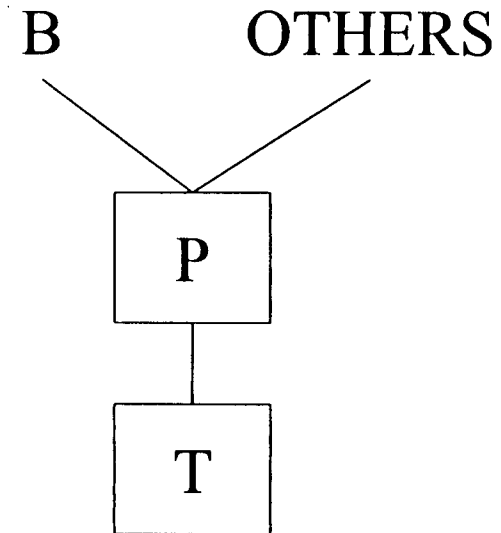

**Facts:** T redeems all of the T stock owned by A for \$90x. P then acquires all the remaining T stock from B in exchange for P stock in a purported "B" reorganization.

# Asset Transfers To Corporations

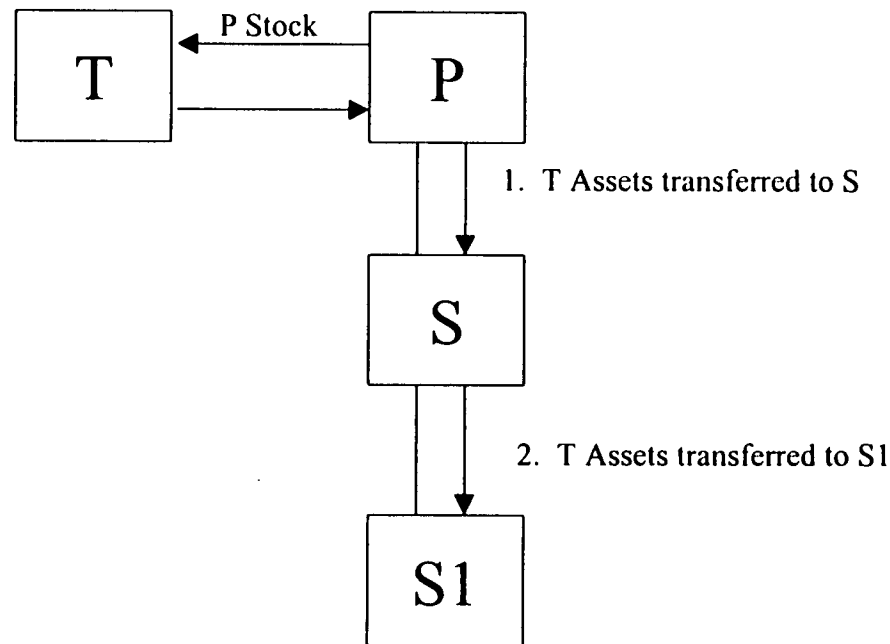

**Facts:** T merges into P and T shareholders exchange their T stock for P stock. P transfers the T assets to S, which immediately transfers them to S1.



# Continuity of Business Enterprise: Cross-Chain Transfers

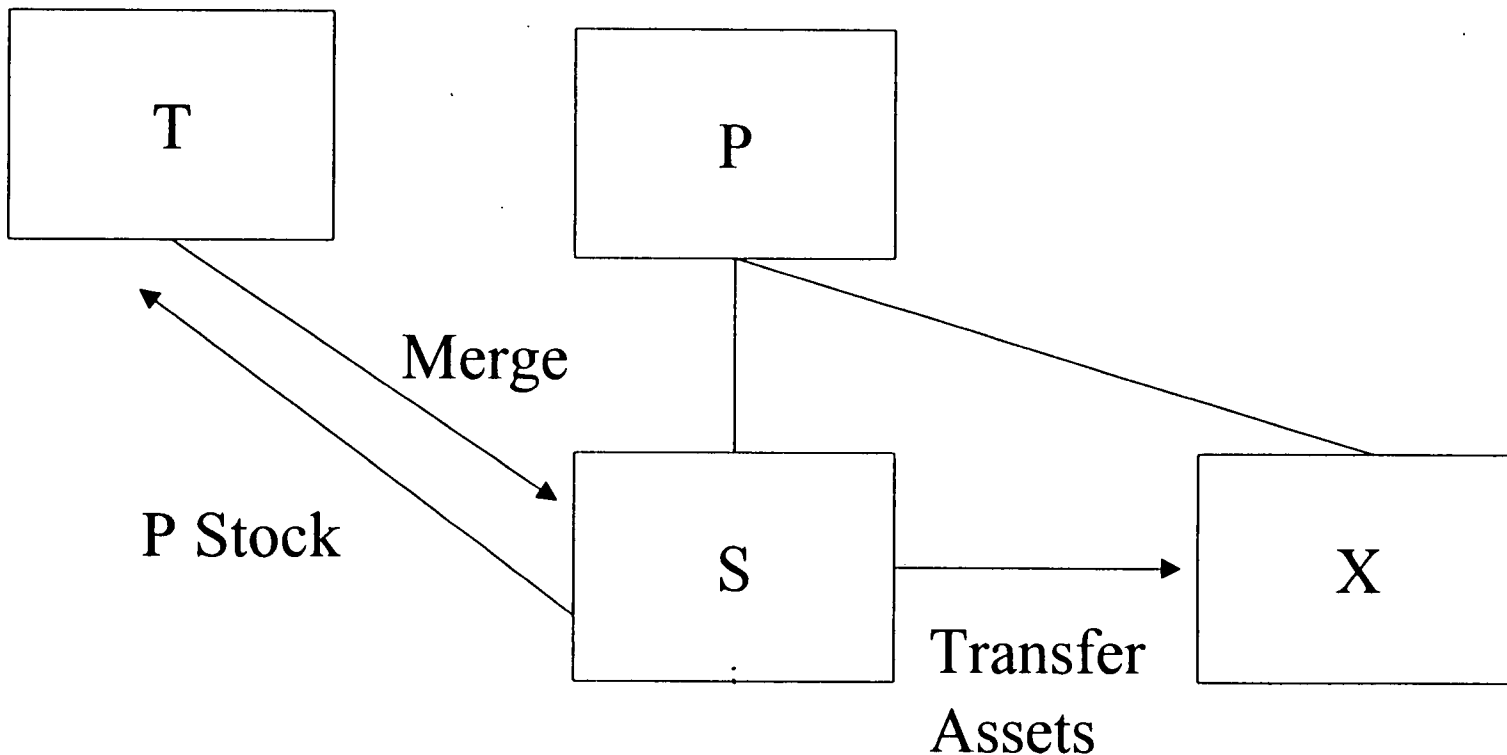

Facts: P owns 100% of the stock of S. T, an unrelated corporation, merges into S, with the T shareholders receiving P stock for their T stock. Immediately thereafter, S transfers the T assets to X.

# Continuity of Business Enterprise: Cross-Chain Transfers

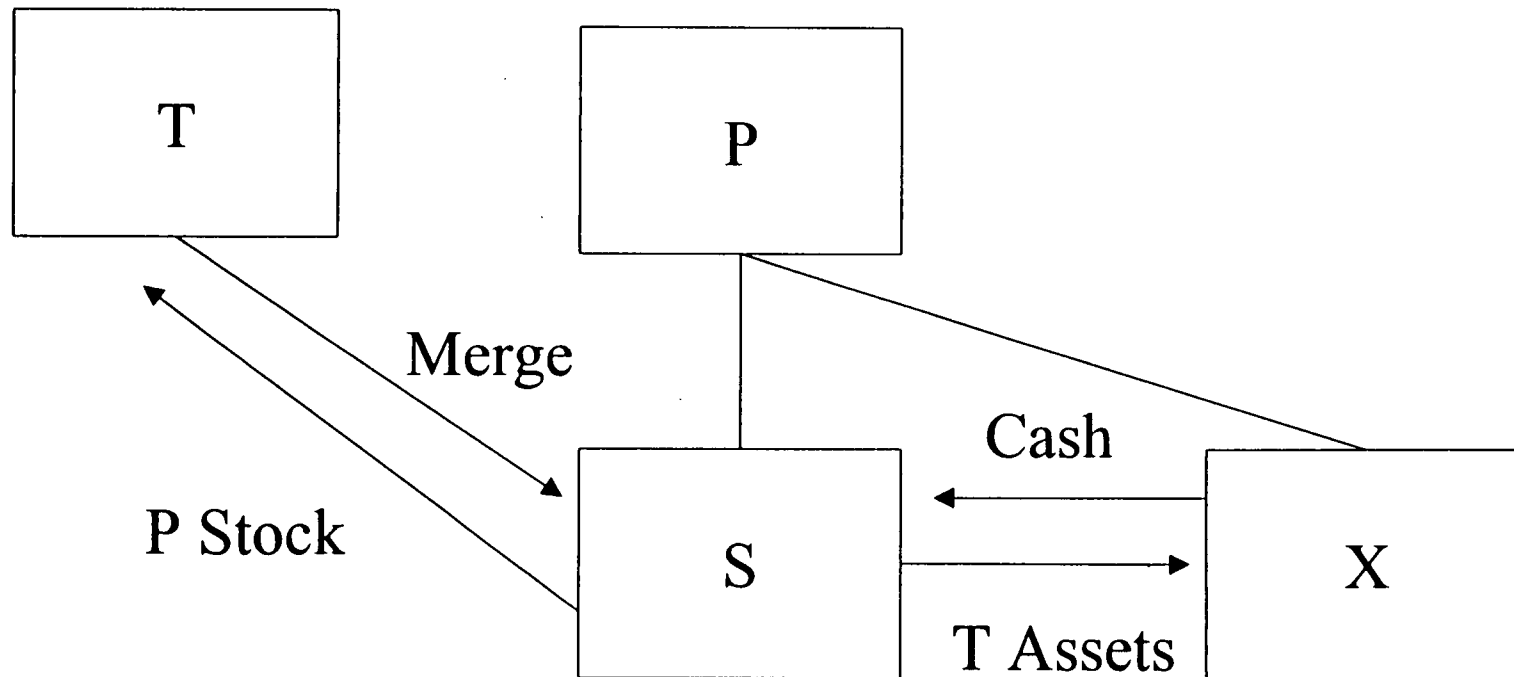

Facts: P owns 100% of the stock of S. T, an unrelated corporation, merges into S, with the T shareholders receiving P stock for their T stock. Immediately thereafter, S transfers the T assets to X in exchange for cash.

# Continuity Of Business Enterprise

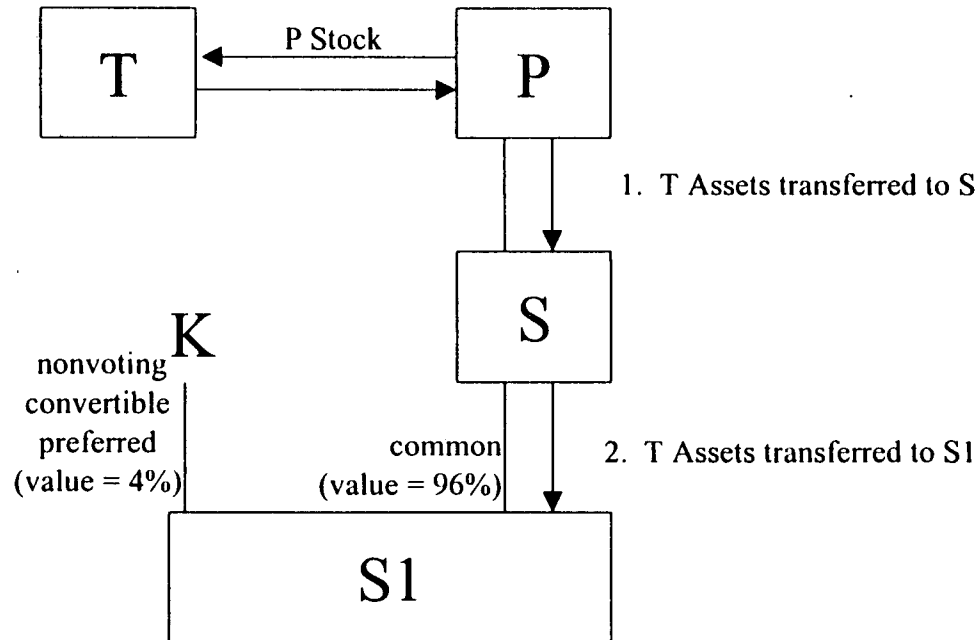

**Facts:** P owns all of the stock of S which owns all of the common stock of S1. Nonvoting convertible preferred stock of S1 is held by a third party but its value is only 4% of S1's total value. In a merger of T into P, the T shareholders exchange their T stock for P stock. Immediately following the merger, P transfers the T assets to S which transfers them to S1.

# Continuity Of Business Enterprise

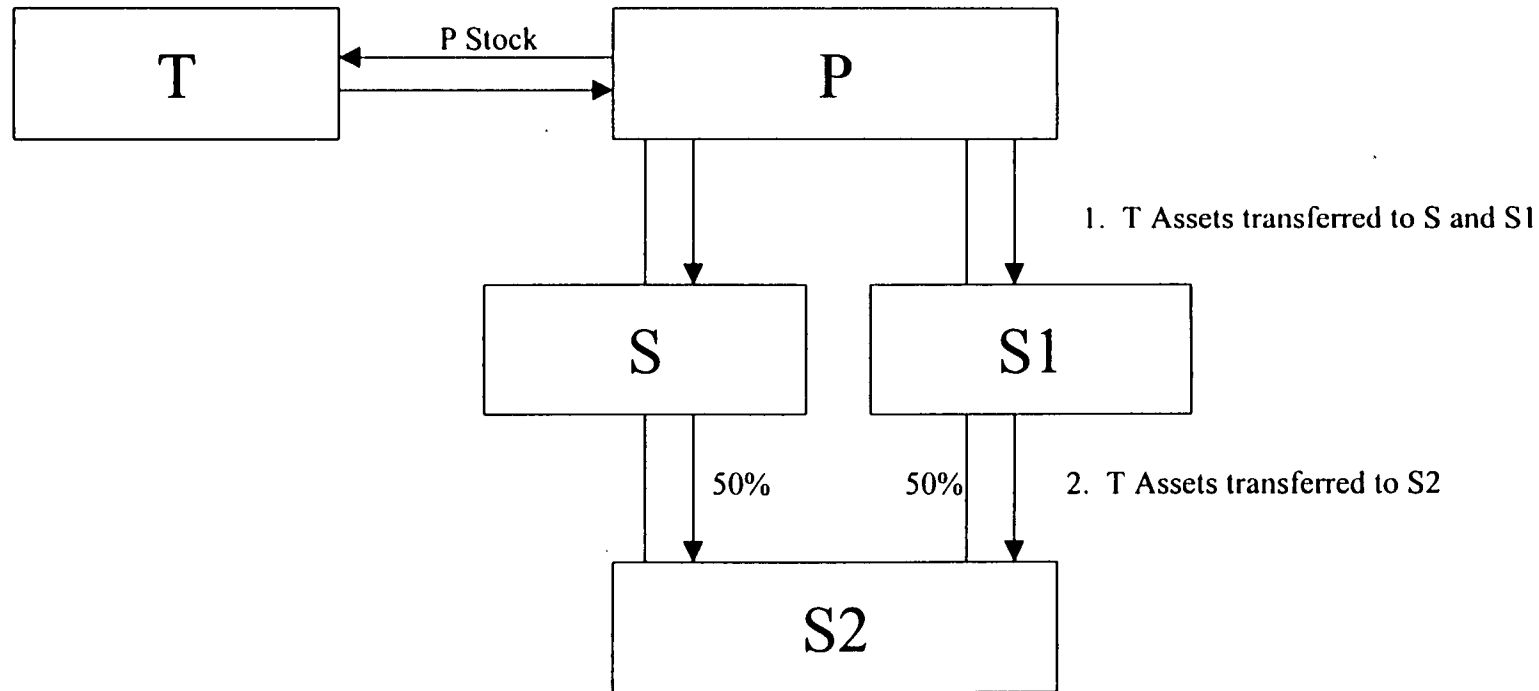

**Facts:** P owns all of the stock of S and S1. S and S1 each own 50% of the stock of S2. In a merger of T into P, the T shareholders exchange their T stock for P stock. Immediately following the merger, P transfers the T assets to S and S1 which transfer them to S2.

# Transfers to Partnerships

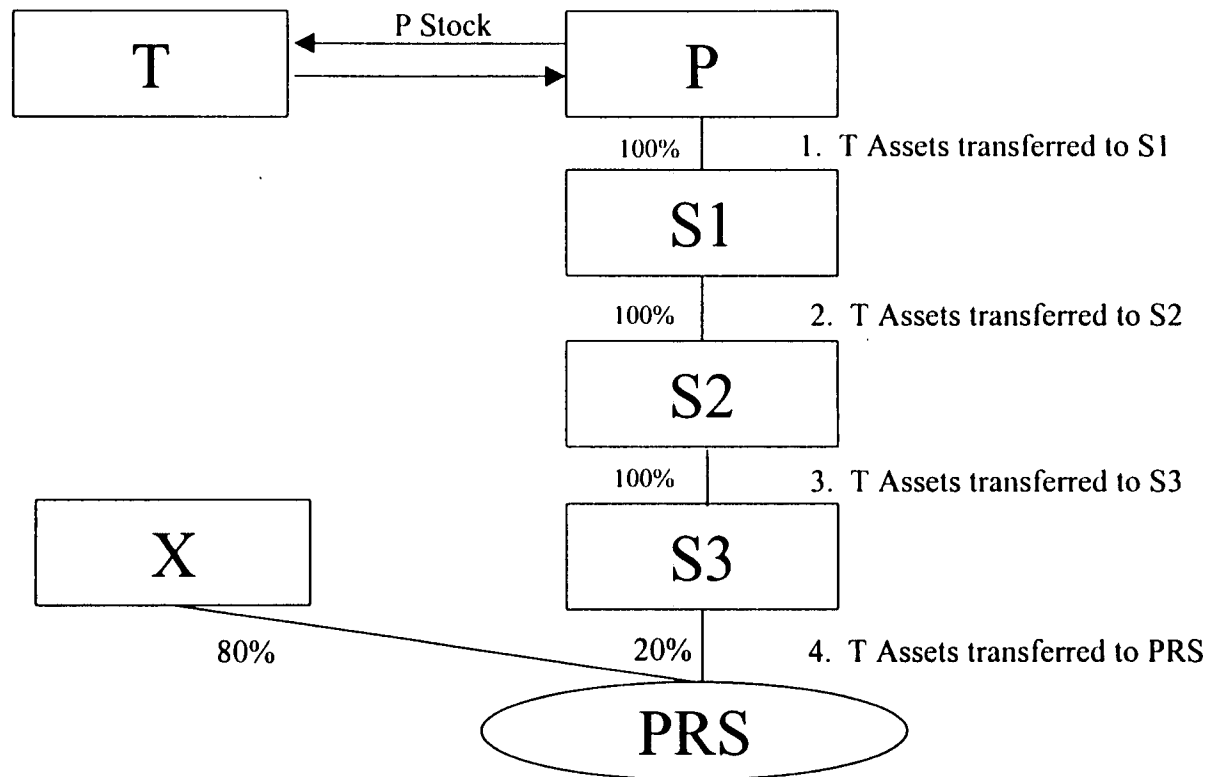

**Facts:** P owns all of the stock of S1, which owns all the stock of S2, which owns all the stock of S3. In a merger of T into P, the T shareholders exchange their T stock for P stock. Immediately following the merger, P transfers the T assets to S1, which transfers the T assets to S2, which transfers the assets to S3. S3 then transfers the assets to a partnership, PRS, in exchange for a 20% interest in PRS. X Corporation, an unrelated party, transfers cash to PRS in exchange for an 80% interest in PRS. S3, in its capacity as a partner, makes significant business decisions and regularly participates in the overall supervision, direction, and control of the PRS business.

# Transfers To Partnerships

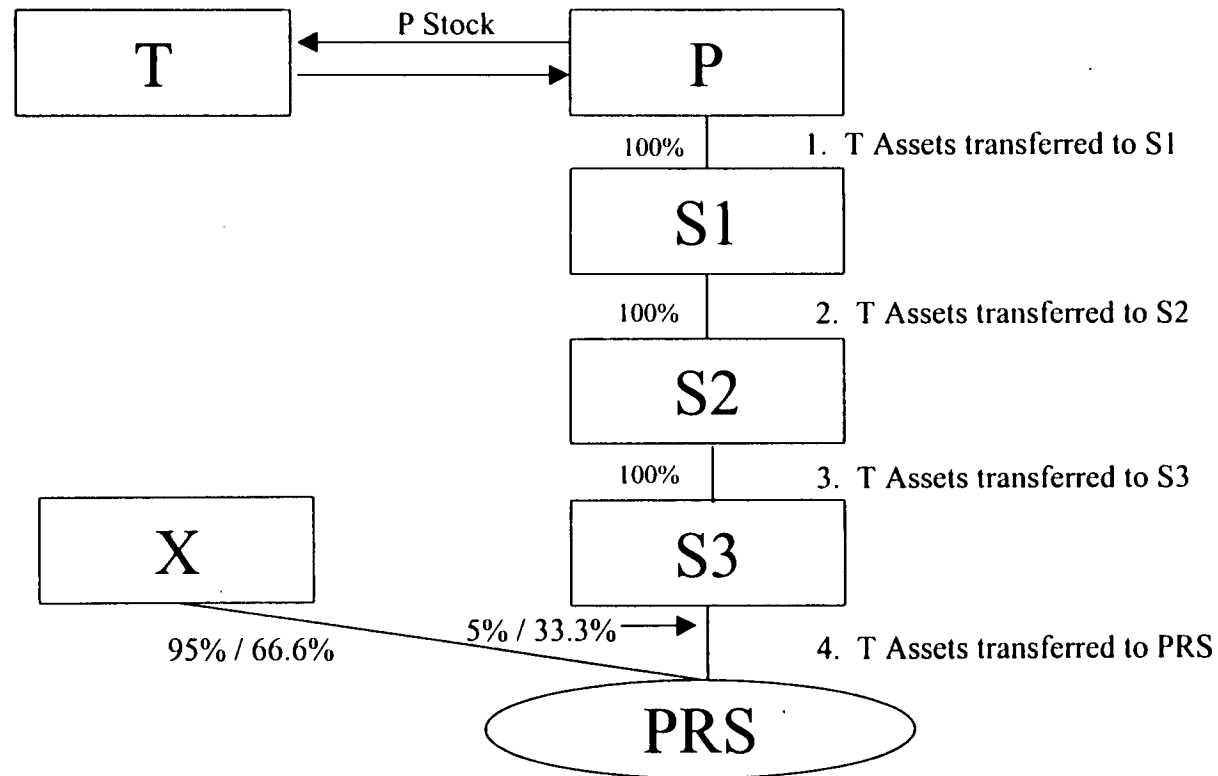

**Facts:** Assume the same facts as in the previous example, except S3 owns a 5% interest in PRS and X owns a 95% interest in PRS prior to S3's transfer of T's assets to PRS. Assume further that S3 does not perform active and substantial management functions, and S3's interest in PRS increases from 5% to 33 1/3% as a result of the transfer.

# Continuity of Business Enterprise: Transfers To Partnerships

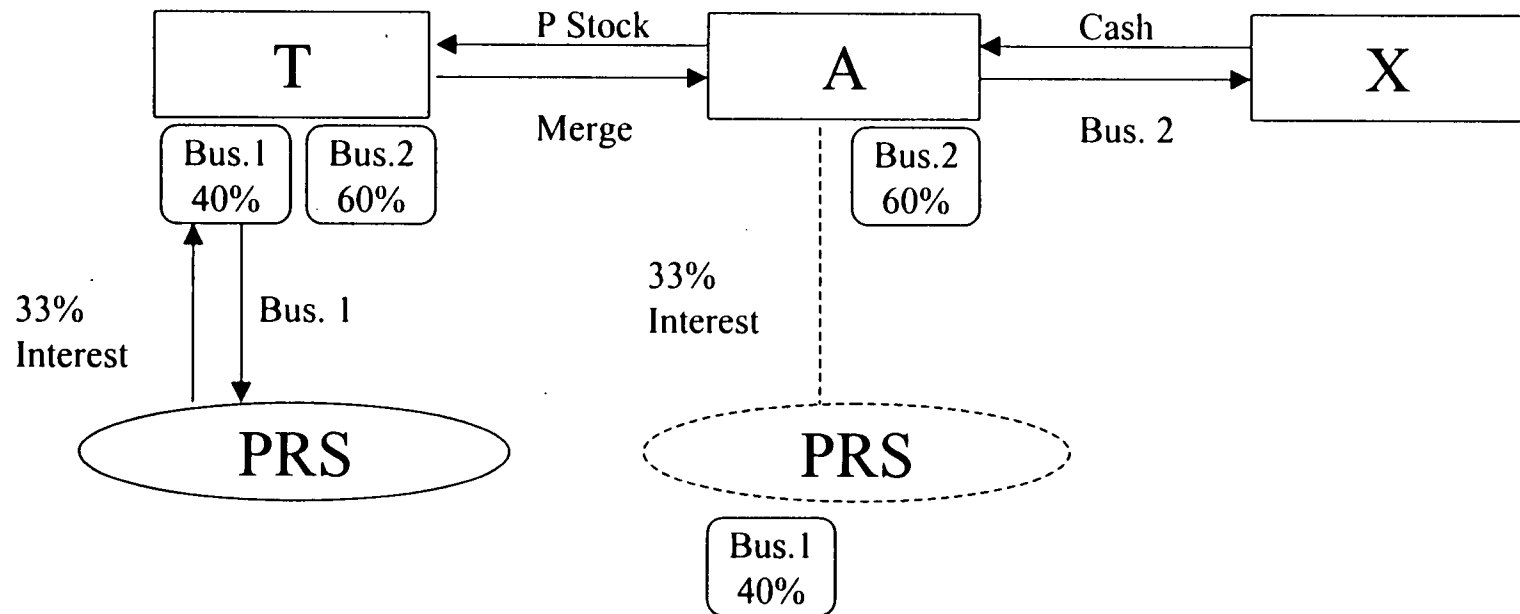

**Facts:** Target operates two businesses, Business 1, which comprises 40% of its operations and Business 2, which comprises 60%. Target transfers Business 1 to a partnership in exchange for a 33% interest in such partnership. Target then merges into Acquirer, and Acquirer sells Business 2 to X Corporation, an unrelated third party.

# Transfers Of Stock To Partnerships

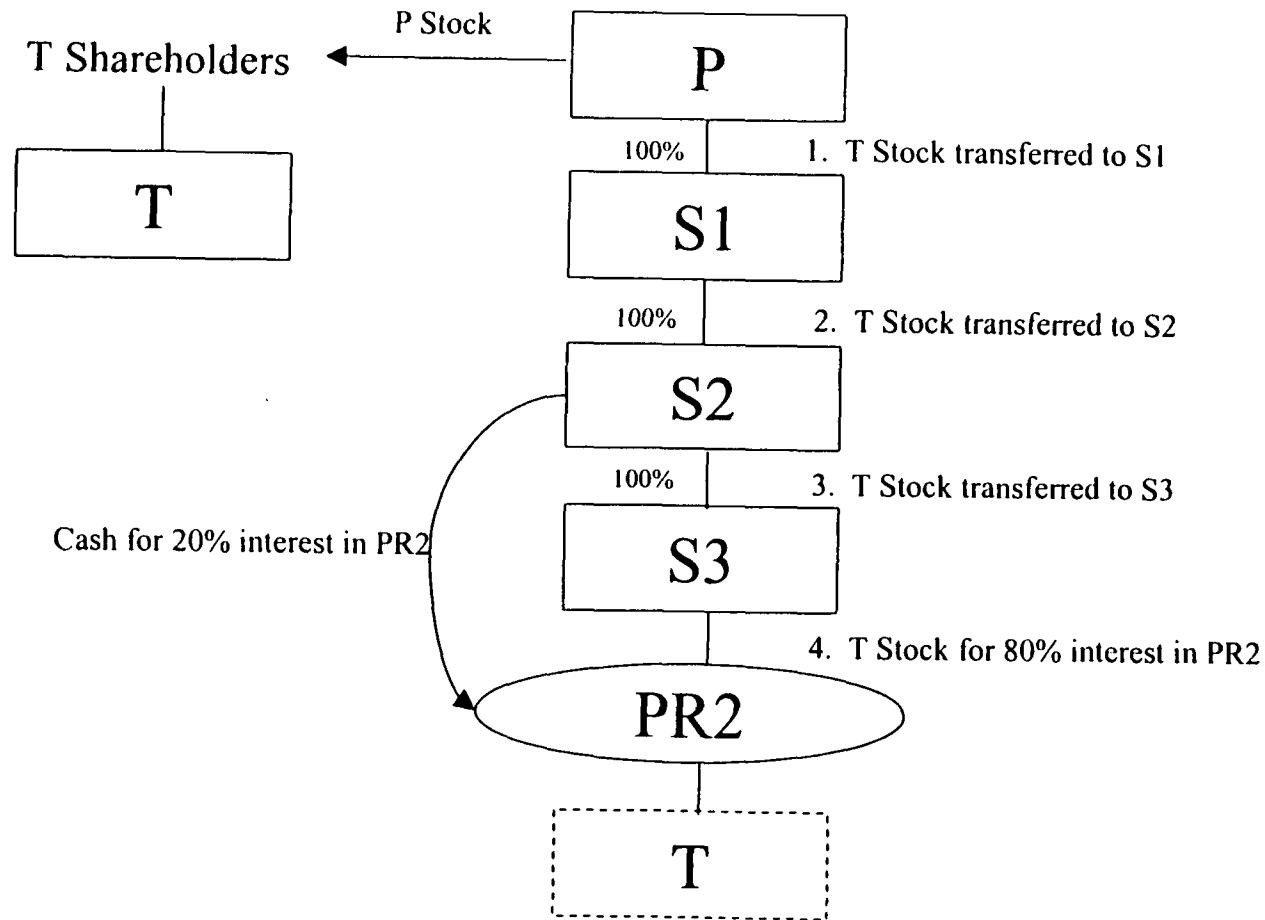

**Facts:** Assume the same facts as in the previous example, except (1) P acquires all of T's stock from T's shareholders, instead of its assets, solely in exchange for P stock, (2) the T stock is transferred down the chain to S1, S2, and then S3, and (3) S3 and S2 form a new partnership, PR2, to which S3 contributes the T stock in exchange for an 80% interest in PR2 and S2 contributes cash in exchange for a 20% interest in PR2.



# Aggregation Of Partnership Interests

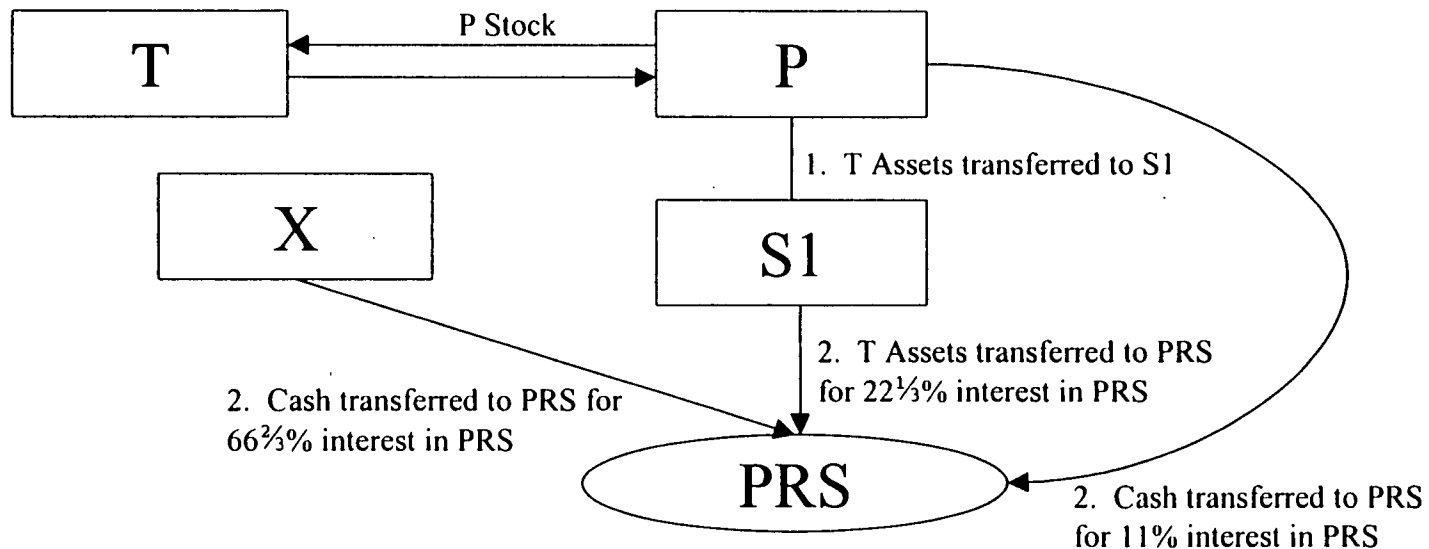

**Facts:** P owns all of the stock of S1. T merges into P. P transfers its T assets to S1, which transfers them to PRS in exchange for a 22 1/3% interest in PRS. PRS uses the historic T assets in its business. P and X each transfer cash to PRS in exchange for partnership interests. P receives an 11% interest in PRS, and X receives a 66 2/3% interest in PRS. No member of P's qualified group performs active and substantial management functions for PRS.

# Tiered Partnerships

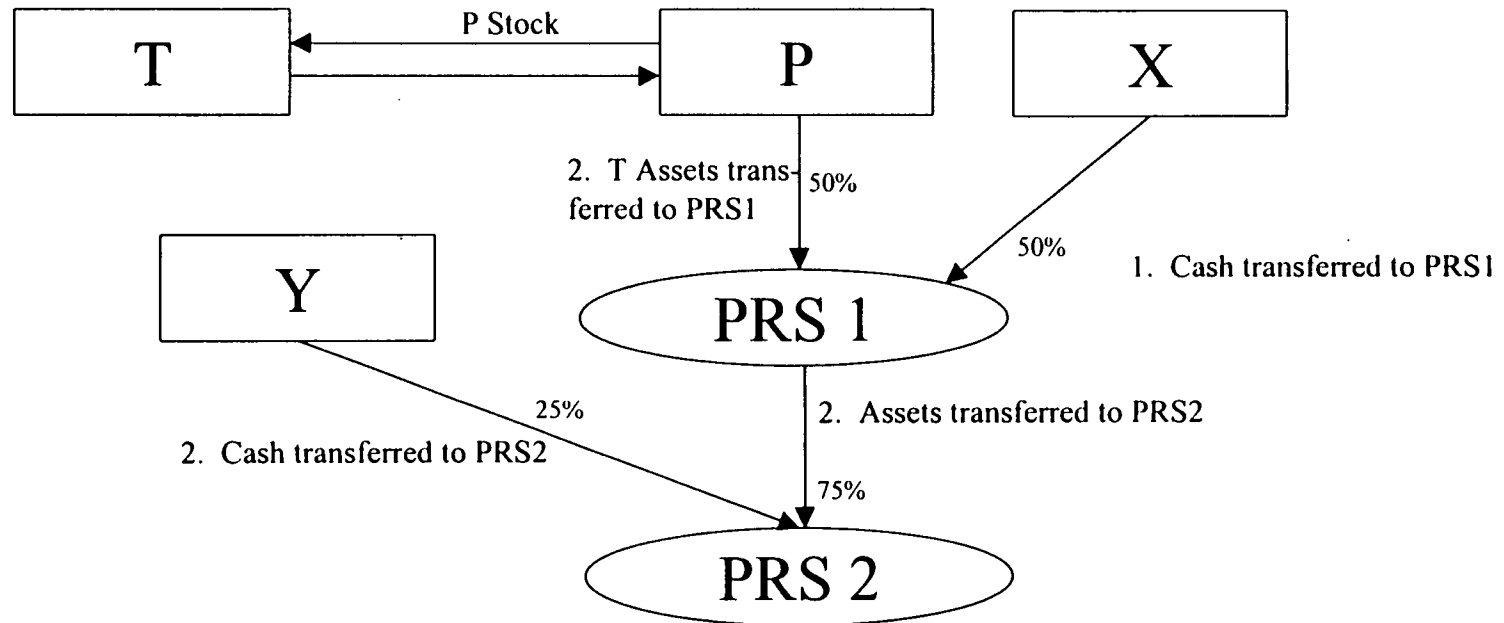

**Facts:** T merges into P solely in exchange for P stock. P transfers all of its T assets to a partnership, PRS1, in exchange for a 50% interest in PRS1. P does not perform active and substantial management functions as a partner in PRS1. X Corporation, an unrelated party, contributes cash in exchange for the remaining 50% interest in PRS1. PRS1 then transfers the T assets to a second partnership, PRS2, in exchange for a 75% interest in PRS2. PRS2 uses the historic T assets in its business. PRS1 does not perform active and substantial management functions as a partner of PRS2. Y Corporation, an unrelated party, contributes cash in exchange for the remaining 25% interest in PRS2.

# “Substantially All”

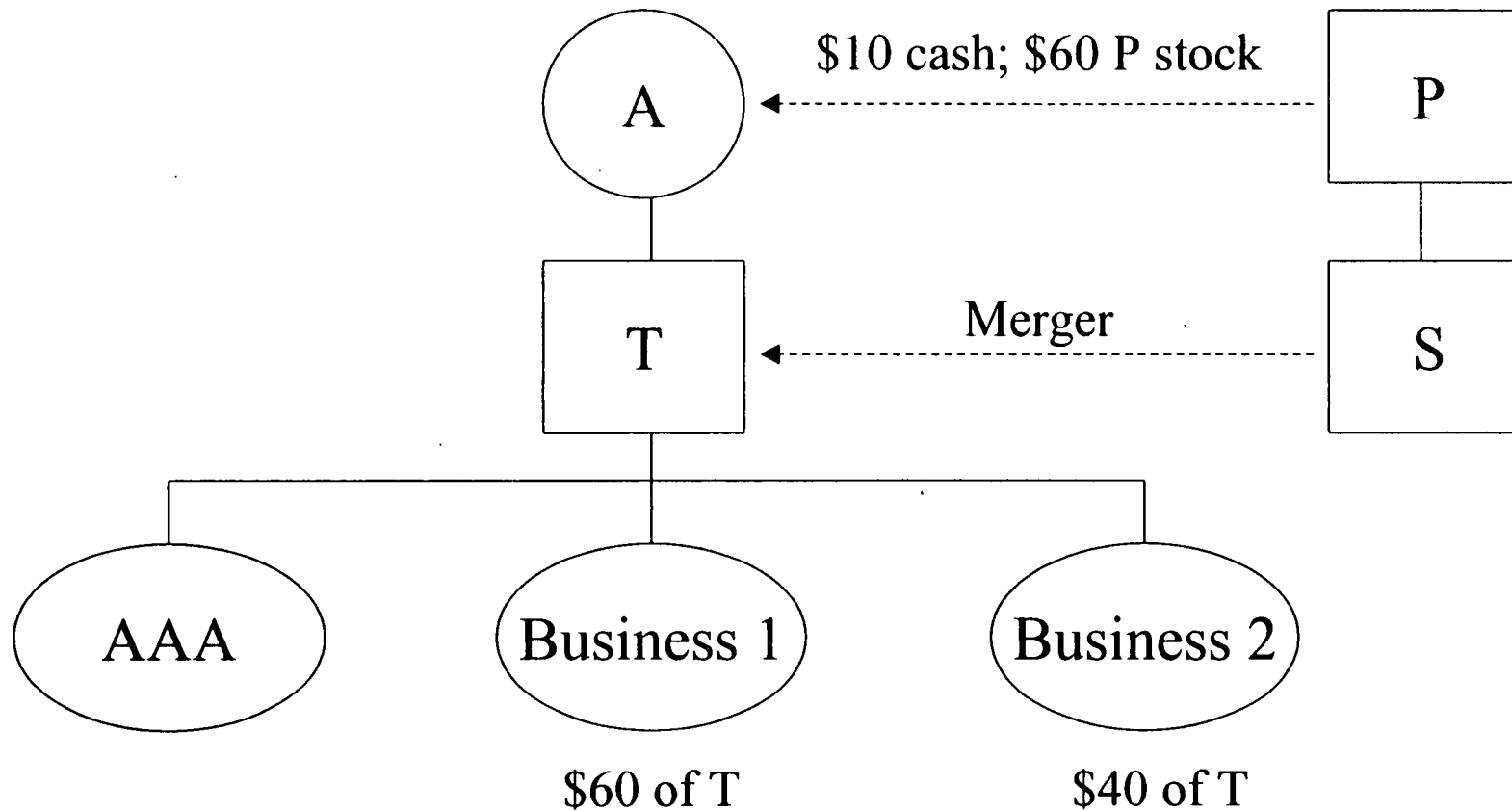

## **Facts**

T is an S corporation with a AAA of \$30 and total value of \$100. T has two divisions: Business 1 (\$60 value) and Business 2 (\$40 value). Individual A owns all the T stock. T has no debt

P, an unrelated corporation, wishes to acquire T in a reverse triangular merger with P's new, wholly-owned subsidiary, S, under sections 368(a)(1)(A) and (a)(2)(E). A will receive \$10 cash and \$60 worth of P voting stock.

# “Substantially All” Continued

## Questions

1. Immediately before the merger T distributes its \$30 AAA to A in excess cash.
2. Suppose that, immediately after the merger, P contributes \$30 cash to T.
3. Suppose the distribution is a T borrowing of \$30 from an unrelated person.
4. P does not want Business 2. Immediately before the merger T sells the Business 2 for \$40 cash and retains the cash for use in Business 1.
5. Would the result in 4. change if the proceeds of the sale of Business 2 were used to retire T debt?
6. Would the results change if the consideration paid by P consisted solely of P voting stock?

# “Substantially All” Continued

## Authorities

Code Sections 368(a)(1)(A), (a)(1)(B), (a)(2)(E)

Reg. § 1.368-2(j)

Rev. Proc. 77-37, 1977-2 C.B. 568 (90% net assets - 70% gross assets)

Rev. Proc. 86-42, 1986-2 C.B. 722 (90% net assets - 70% gross assets)

Rev. Rul. 57-518, 1957-2 C.B. 213 (Nature and use of assets)

Rev. Rul. 67-448, 1967-2 C.B. 144 (Forced “B” merger)

Rev. Rul. 71-266, 1971-1 C.B. 262 (Distribution of S earnings)

Rev. Rul. 72-343, 1972-2 C.B. 213 (“Interim financing” of target by acquiring corporation treated as taxable “boot” under section 361(a))

Rev. Rul. 75-360, 1975-2 C.B. 110 (Distribution followed by re-contribution)

Rev. Rul. 88-48, 1988-1 C.B. 117 (Asset substitution permitted)

Robert H. Wellen, *New Guidance Is Needed for the “Substantially All” Rule as Applied to Acquisitions*, 79 J. Tax’n 280 (Nov. 1993)

Robert H. Wellen, *More Problems Complicate the Application of “Substantially All” To Acquisitions*, 79 J. Tax’n 366 (Dec. 1993)

# “Control” for Voting Stock

**Before:**

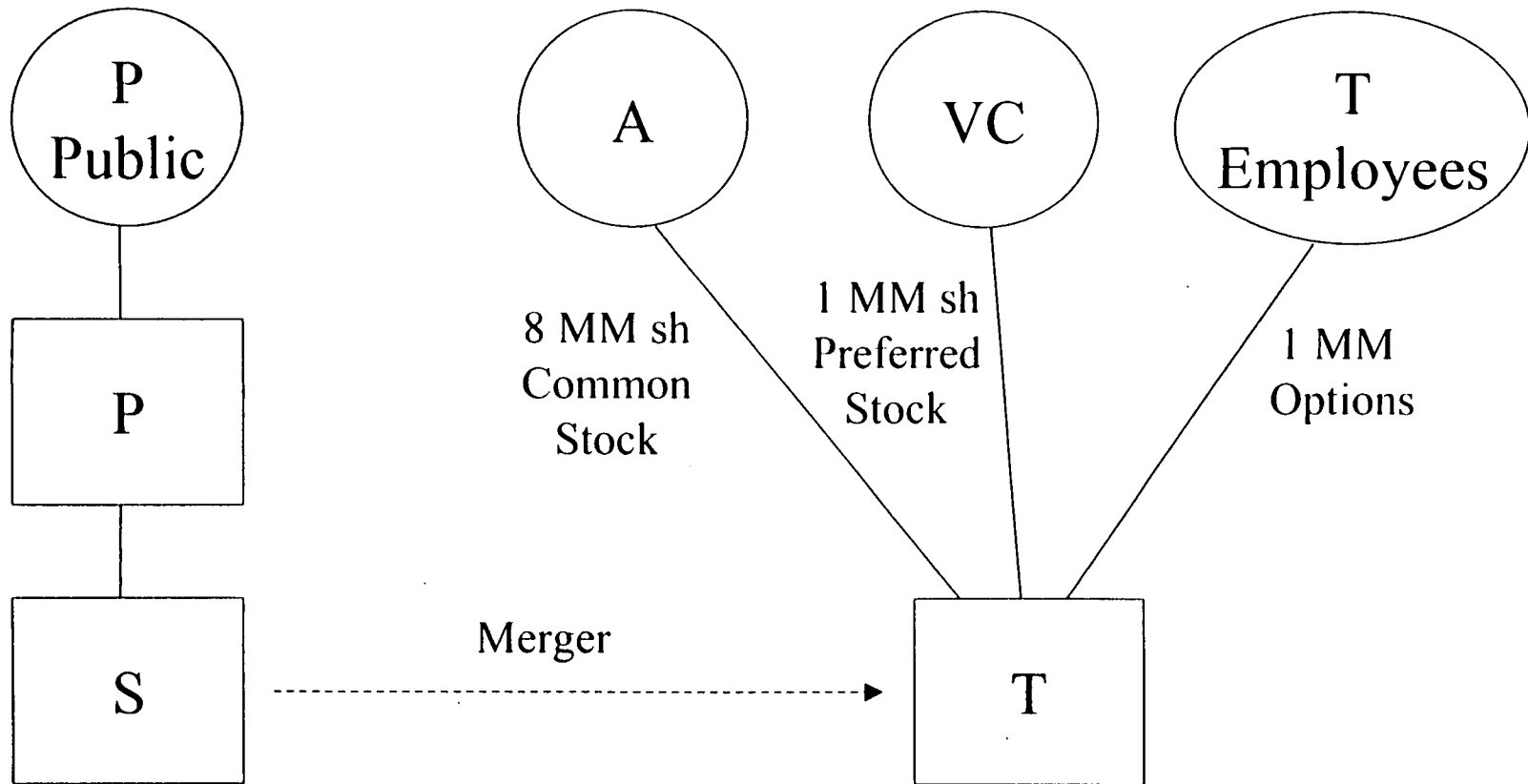

# “Control” for Voting Stock Continued

**After:**

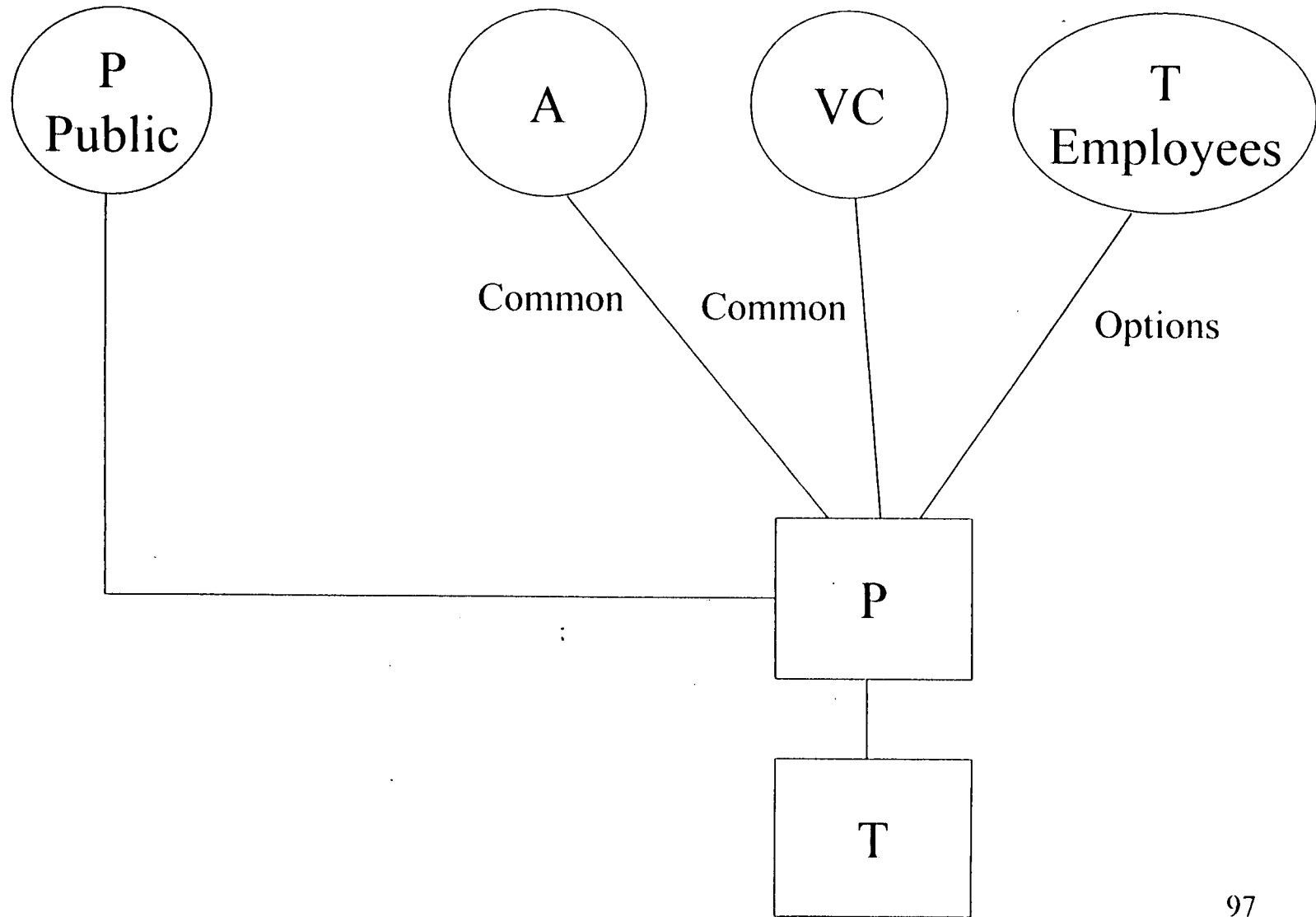

# “Control” for Voting Stock Continued

## **Facts**

T is in a high-technology business. Individual A founded T five years ago, and since then T has experienced rapid growth. A owns all 8 million shares of T common stock.

VC, a venture capitalist, owns all 1 million shares of T preferred stock. The preferred stock is convertible into common stock, share-for-share, and it votes on some corporate matters but not for directors.

T's employees own 1 million stock options, exercisable at \$0.05 per share and vesting after 3 years.

P is a publicly traded corporation. P stock has trades at about \$2 per share. P wishes to acquire T. P forms a new subsidiary, S, which is merged into T. A and VC receive one share of P common stock for each share of T common and preferred stock. P issues P stock options on the same terms as the T options.



# “Control” for Voting Stock Continued

## Questions

1. Will the merger qualify as a tax-free reorganization?
2. Will the treatment change if VC receives P preferred stock with terms like the terms of the T preferred stock it now holds? Cash?
3. Will the treatment change if P (instead of VC) owns the T preferred stock?
4. Will the treatment change if T is merged into S instead of the other way around?

## Authorities

Code sections 356(a), 368(a)(2)(E) and 368(c)

Reg. § 1.1361-1(l)(4)(iii) (certain options to acquire stock treated as second class of stock for subchapter S qualification purposes)

Reg. § 1.1504-4 (certain options to acquire or sell stock treated as exercised for consolidated return purposes)

Proposed Reg. §§ 1.355-6(c)(3)(ii) and (c)(3)(vi)(B) (certain stock options treated as exercised for purposes of section 355(d) – “reasonably certain to be exercised” – certain security arrangements and compensatory options excluded)

# “Control” for Voting Stock Continued

## Authorities Continued

Proposed Reg. §§ 1.355-7(a)(7)(i)(A), (a)(7)(iii)(A) & (B) (certain stock options treated as exercised for purposes of section 355(e) – “more likely than not” exercised – certain security arrangements and compensatory options excluded)

Rev. Rul. 82-150, 1982-2 C.B. 110 (call option as treated as exercised where optionee paid \$70x for option to purchase stock worth \$100x for \$30x)

Rev. Rul. 85-87, 1985-1 C.B. 268 ( put option on stock treated as exercised where market price was “substantially less” than the exercise price; spread between the exercise price and value, term of put, premium paid, historic volatility in FMV of stock, and “other objective factors” analyzed as factors suggesting “substantial likelihood” of exercise)

Rev. Rul. 83-98, 1983-2 C.B. 40 (convertible note treated as equity because of high probability of conversion; note was worth \$600 at maturity but was convertible into 50 shares of common stock with FMV of \$1000)

*Victorson v. Commissioner*, 326 F.2d 264 (2d Cir. 1964), *aff’g* T.C. Memo 1962-231

(compensatory stock option not treated stock issuance, even though exercise price was small fraction of FMV)

*Simmons v. Commissioner*, T.C. Memo 1964-237 (same)

*Comtel Corporation v. Commissioner*, 45 T.C. 294 (1965), *aff’d* 376 F.2d 791 (2d Cir. 1967),

*cert. denied* 389 U.S. 929 (1967) (sale of hotel with option to repurchase at price equal to purchase price plus interest factor treated as financing arrangement)

# “Control” for Voting Stock Continued

## Authorities Continued

*Penn Dixie Steel Corp. v. Commissioner*, 69 T.C. 837 (1978) (non-simultaneous reciprocal put and call not treated as completed sale under “strong proof” standard)

*Tennessee Natural Gas Lines, Inc. v. Commissioner*, 71 T.C. 74 (1978) (real estate option to purchase treated as transferring burdens and benefits of ownership)

*Belz Investment Co. v. Commissioner*, 72 T.C. 1209 (1979) (real estate sale and leaseback with option to repurchase upheld because exercise not “foregone conclusion”)

*Progressive Corp. v. United States*, 970 F.2d 188 (6th Cir. 1992) (remand to district Court for determination whether options were sufficiently “deep in the money” to be treated as exercised)

*Kwiat v. Commissioner*, T.C. Memo. 1992-43 (1992) (reciprocal put and call on equipment shifted tax ownership; *Penn Dixie* distinguished)

*Rogers v. United States*, 99-2 USTC ¶ \_\_\_\_, : AFTR 3d \_\_\_\_ (D. Kan. June 11, 1999) (nonrecourse secured loan by corporation to shareholder plus option -- exercised early in following year -- to call shareholder’s stock at price equal to loan balance, treated as completed stock redemption; bad debt deduction to corporation disallowed)

U.S. Treasury Department, General Explanations of Administration Revenue Proposals (February 1999), 128 (proposal to amend Code section 368(c))

# Bausch & Lomb

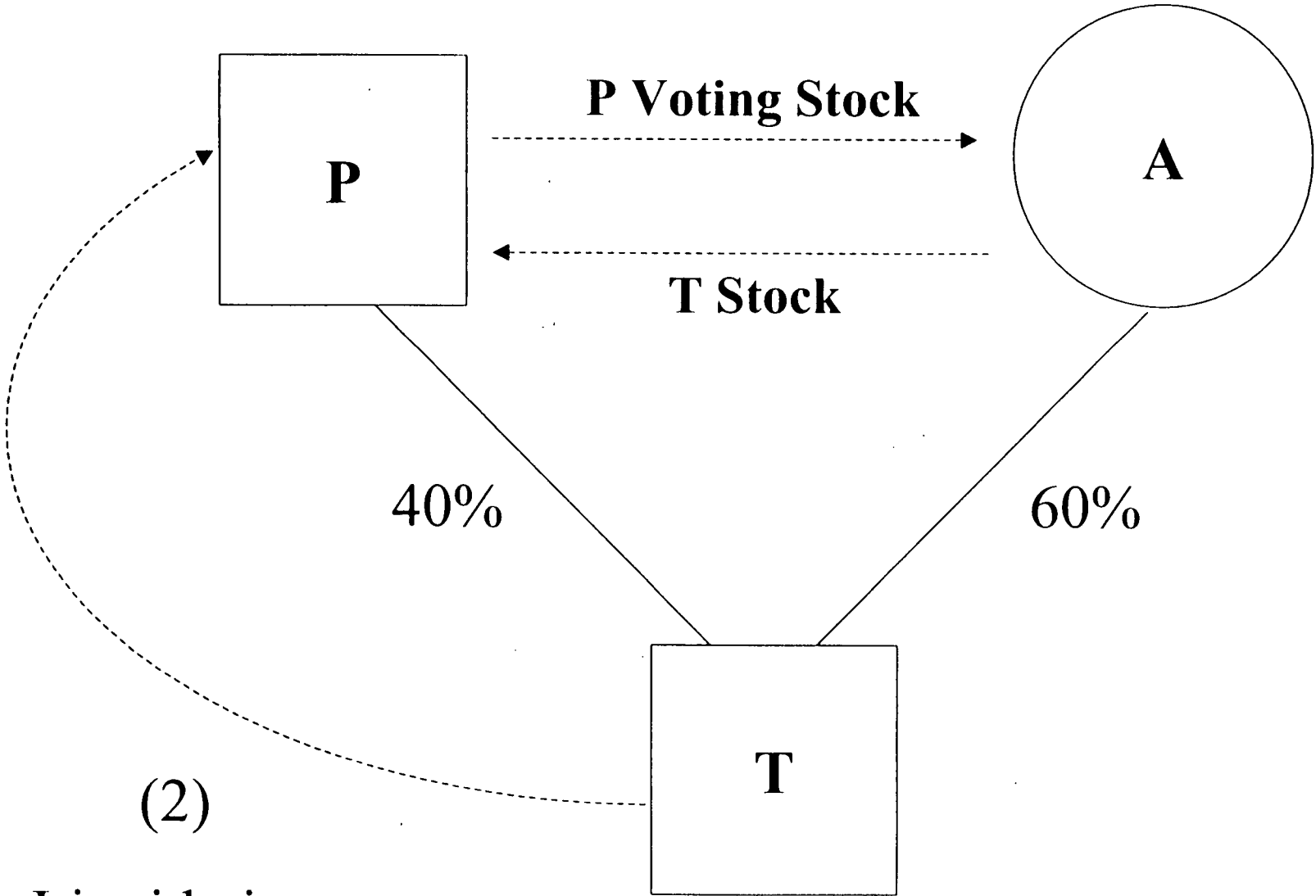

Liquidation

# Bausch & Lomb (continued)

## Facts

P has owned 40% of the stock of T for several years. Individual A owns the remaining 60% of the T stock.

P acquires the remaining 60% of the T stock from A, solely for P voting stock. Immediately thereafter T distributes all its assets to P in liquidation.

## Questions

1. Does the acquisition and liquidation of T qualify as a reorganization?
2. Would the results change if, instead being liquidated, T merged into P?
3. Would the results change if, instead being liquidated, T were merged into an LLC wholly owned by P.
4. P acquires 40% of the T stock for cash from unrelated individual X. shortly thereafter P acquires the remaining 60% of the T stock for P stock from A, and T distributes all its assets to P in liquidation.

# Bausch & Lomb (continued)

## Authorities

Reg. §1.338-2(b)

Proposed Reg. § 1.368 -1(d)(4)

*Bausch & Lomb Optical Co. v. Commissioner*, 30 T.C. 602 (1958), aff'd 267 F.2d 75 (2nd Cir. 1959) (Pre-reorganization ownership by P of T stock invalidated stock for asset Type “C” reorganization)

*American Potash & Chemical Corp. v. U.S.*, 399 F.2d 194 (Ct. Cl. 1968) (Stock for stock exchange acquired in separate transactions followed by liquidation neither a valid stock for stock or stock for assets reorganization)

*King Enterprise, Inc. v. United States*, 418 F.2d 511 (Ct. Cl. 1969) (Cash and stock purchase followed by planned merger treated as valid Type “A” reorganization)

Rev. Rul. 54-396, 1954-2 C.B. 147 (Pre-reorganization ownership by P of T stock invalidated stock for asset Type “C” reorganization)

Rev. Rul. 67-274, 1967-2 C.B. 141 (Stock for stock exchange followed by liquidation tested as stock for asset Type “C” reorganization)

Rev. Rul 69-294, 1969-1 C.B. 110 (*Bausch & Lomb* doctrine applied in stock-for-stock Type “B” reorganization)

Rev. Rul. 90-95, 1990-2 C.B. 67 (Qualified stock purchase followed by liquidation, separate transactions respected)

# Section 355 - Expansion

## PLR 199937014

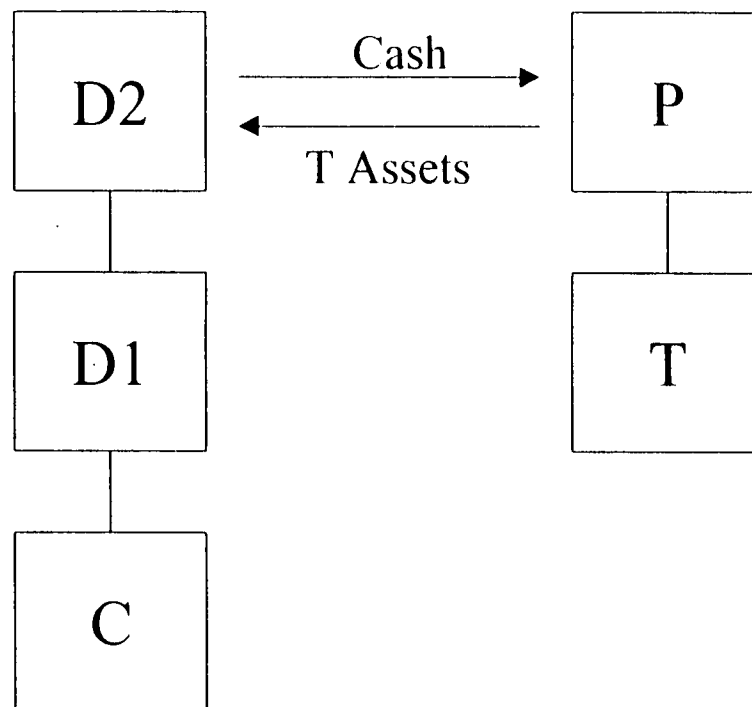

FACTS: Both D2 and D1 are engaged in the active conduct of a five-year trade or business. D1 acquired the assets of T in a taxable transaction and contributed those assets to newly formed C. Prior to and following its acquisition, T has been engaged in the installation of the types of products manufactured by D1. Prior to the acquisition neither D1 nor D2 had been engaged in the installation of their products. May D1 distribute the stock of C tax-free under section 355? See Treas. Reg. § 1.355--3(b)(3)(ii).

## Basic Morris Trust Structure

1.

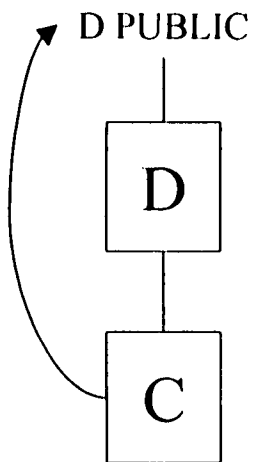

2.

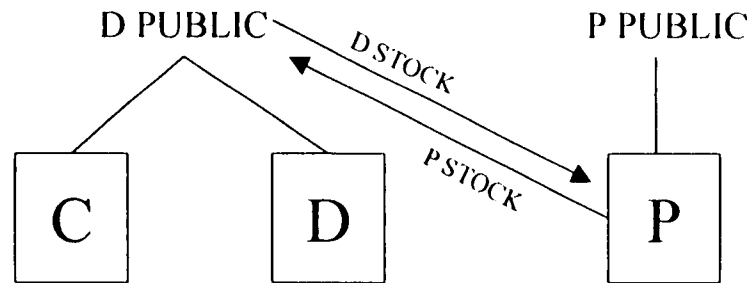

3.

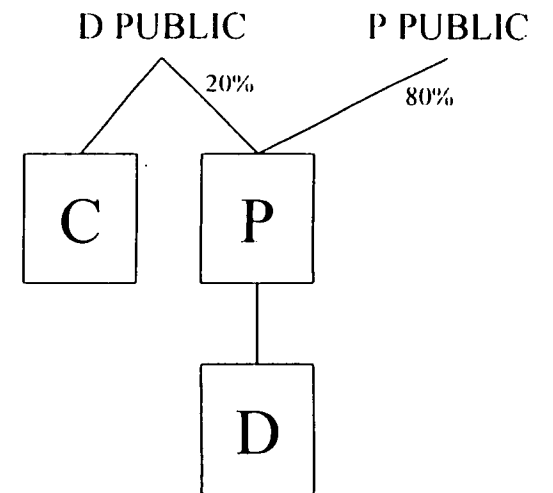



## Section 355(e) Applies

1.

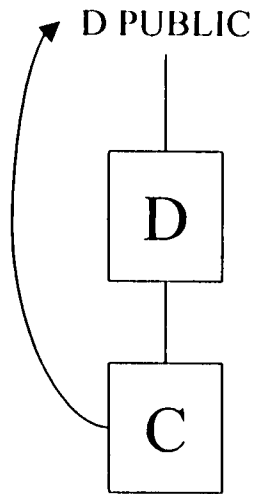

2.

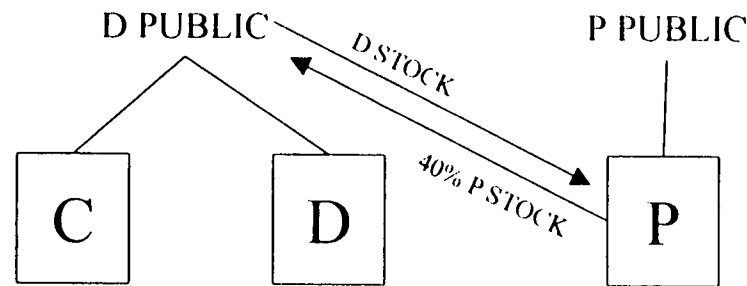

3.

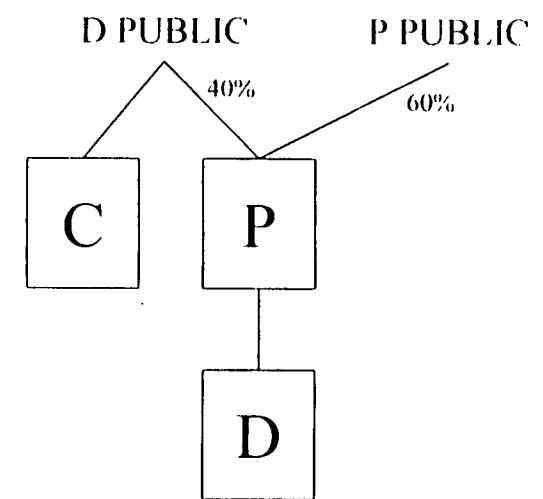

**FACTS:** A publicly traded corporation (“D”) owns all the stock of a controlled corporation (“C”). D has an adjusted basis in its C stock of \$100, and the fair market value of its C stock is \$150. In order to facilitate an acquisition of D by a third corporation (“P”), D distributes its C stock to its shareholders. Within two years, P acquires all the stock of D in a section 368(a)(1)(B) reorganization with the shareholders of D receiving 40 percent of the stock of P in exchange for their D stock.

## Section 355(e) Inapplicable

1.

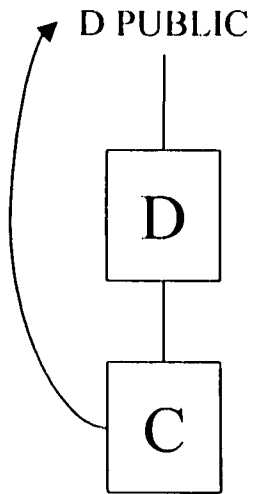

2.

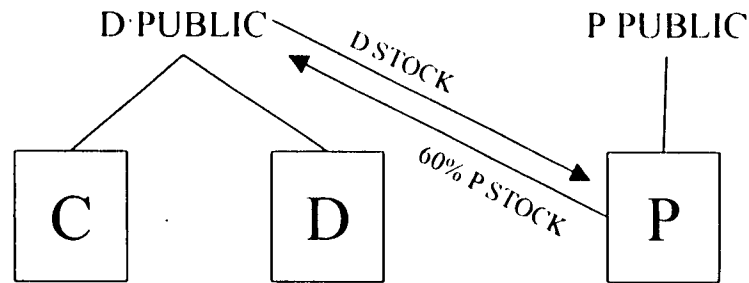

3.

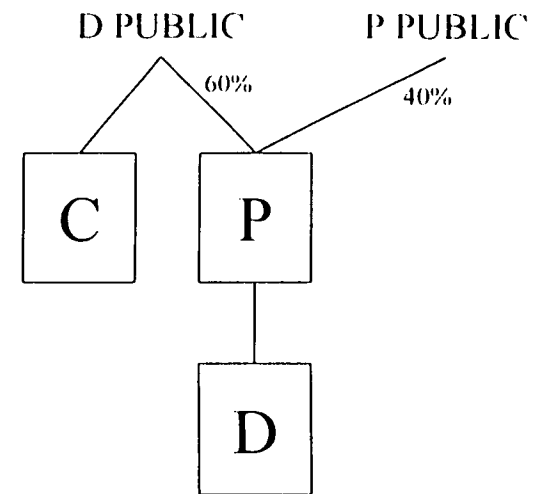

**FACTS:** Same facts as the previous example, except that in the B reorganization, the shareholders of D receive 60 percent of the stock of P in exchange for their D shares.

## Spin-Off and Acquisition

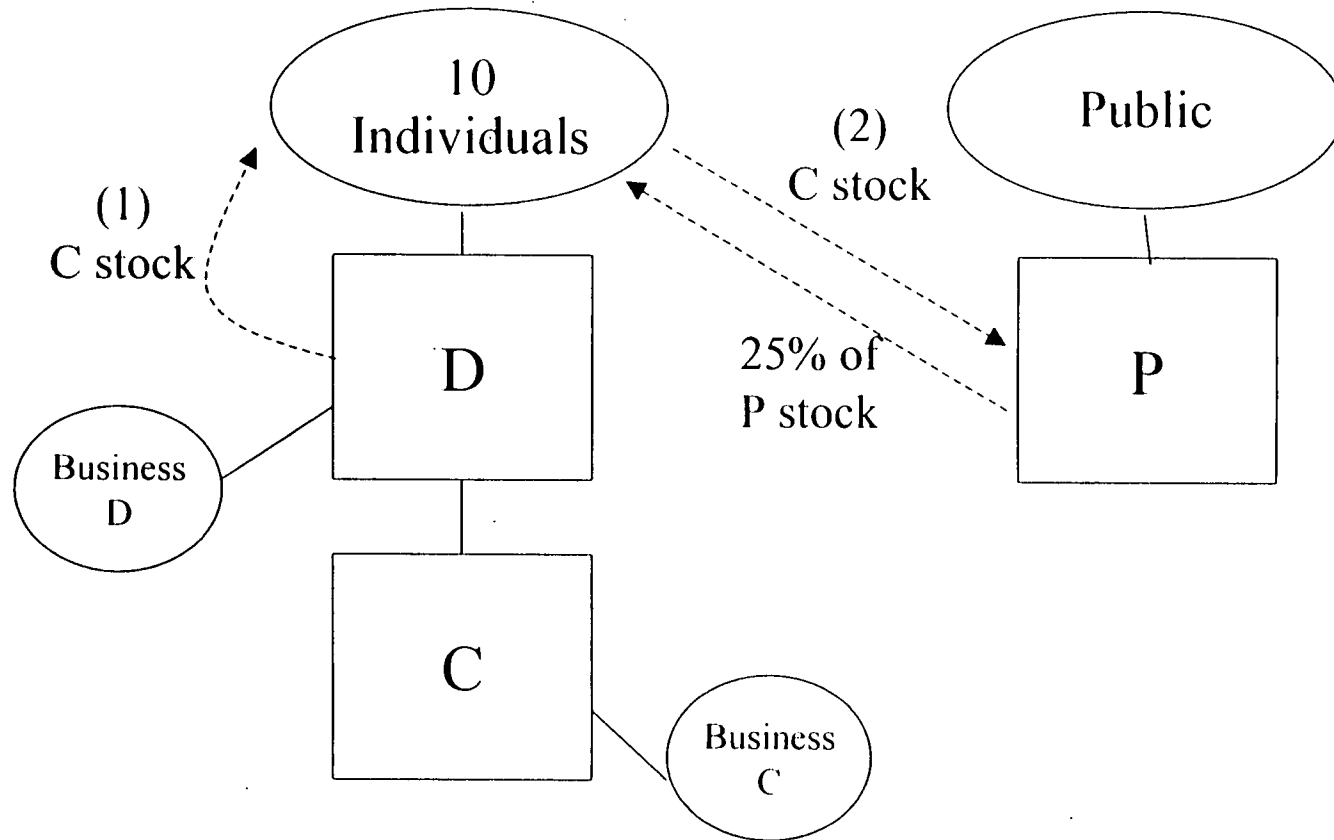

### **Facts**

Ten individual shareholders own all the stock of D. For more than five years, D has engaged in Business D and owned all the stock of C, and C has engaged in Business C.

D distributes the C stock to its shareholders, *pro rata*. At a later date, unrelated public company, P, acquires all the stock of C for 25% of the P stock.

## Spin-Off and Acquisition Continued

### Questions

1. The business purpose for the spin-off is to facilitate the acquisition of C by P, because P is not willing to issue a large block of its stock to D. P's acquisition of C is negotiated at the time of the spin-off and takes place 90 days thereafter, following a vote of the new C shareholders.
  - a. Does it matter if, instead of P acquiring the C stock, C acquires all the stock of P in exchange for 75% of the C stock?
  - b. Does it matter if, instead of P acquiring the C stock, C is merged into P or vice versa?
  - c. Does it matter if individual I owns 10% of the stock of D and C and 51% of the stock of P?
  - d. Does it matter if C is a new corporation, and after the spin-off C acquires the stock of P for 25% of the C stock?

## Spin-Off and Acquisition Continued

2. The business purpose for the spin-off is to reduce the borrowing costs of D and C. C's management is aware of P's interest in acquiring C, but no acquisition is agreed to or negotiated until after the spin-off.
  - a. Does it matter how long after the spin-off the acquisition is negotiated and closed?
  - b. Does it matter if D's management is aware of P's interest in acquiring C and wishes to prevent P from also acquiring D?
3. The business purpose for the spin-off is to allow C to issue 10% of its stock to employees, and C does that after the spin-off. Then P acquires C. After the acquisition the former C shareholders (including the employees) own 51% of the P stock.
4. Would the result in 3. change if, after the acquisition the former C shareholders own 55% of the P stock? Suppose that, 10 years before the spin-off C issued convertible debt, and after the acquisition the debt was convertible into 5% of the P stock.
5. P acquires all the stock of D in exchange for 25% of the P stock. Then D distributes all the stock of C to P, and P, in turn, distributes the C stock to its shareholders (including the former D shareholders), *pro rata*. Does it matter whether D was planning to spin off C before the acquisition?

## Spin-Off and Acquisition Continued

### **Authorities**

Code sections 351(c)(2), 355(e) and (f); 358(g) and 368(a)(2)(H)(ii)

JCT Staff, General Explanation of Tax Legislation Enacted in 1997, JCS-23-97  
(December 17, 1997), 197-206

JCT Staff, General Explanation of Tax Legislation Enacted in 1998, JCS-6-98 (November  
24, 1998), 187-191

Reg. § 1.355-2(d)(2)(iii)(E)

Proposed Reg. § 1.355-7

*Commissioner v. Morris Trust*, 367 F. 2d 794 (4th Cir. 1966)

Rev. Proc. 96-30, 1996-19 I.R.B. 8, Appendix A § 2.07

Rev. Proc. 97-53, 1997-2 C.B. 528, *modifying* Rev. Proc. 97-3, 1997-1 C.B. 507 (deleting  
§ 5.17), *superceding* Rev. Proc. 96-39, 1996-33 I.R.B. 11

Rev. Rul. 68-603, 1968-2 C.B. 148

Rev. Rul. 70-434, 1970-2 C.B. 83

Rev. Rul. 72-530, 1972-2 C.B. 212

Rev. Rul. 78-251, 1978-1 C.B. 89

Rev. Rul. 98-27, 1998-22 I.R.B. 4, *declaring obsolete* Rev. Rul. 96-30, 1996-24 I.R.B. 4,  
*modifying* Rev. Rul. 75-406, 1975-2 C.B. 125

Rev. Rul. 98-44, 1998-37 I.R.B. 4, *declaring obsolete* Rev. Rul. 70-225, 1970-1 C.B. 80,  
*modified by* Rev. Rul. 98-27, 1998-22 I.R.B. 4

## Section 355(f) Applies

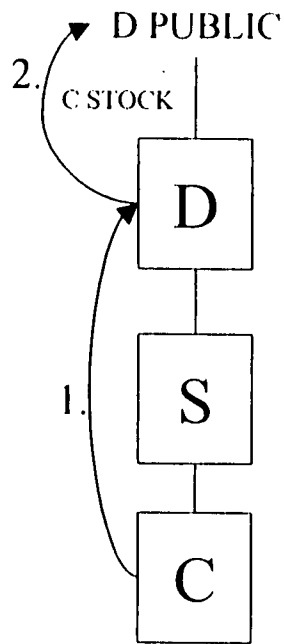

3.

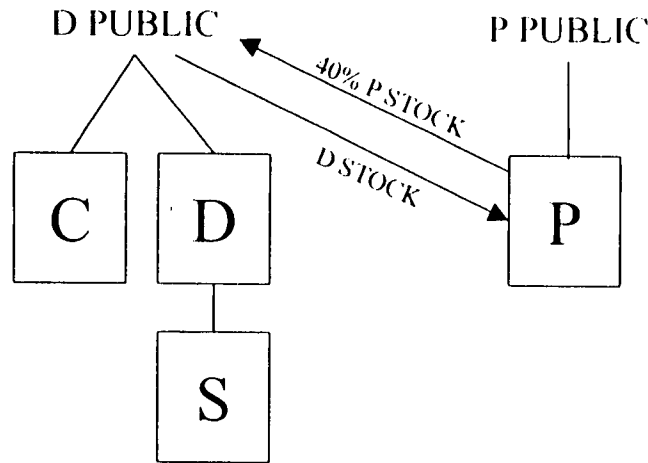

4.

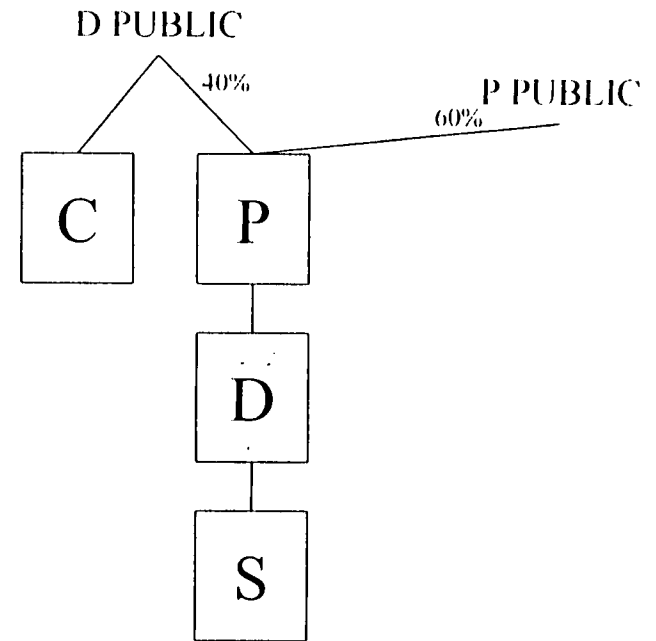

**FACTS:** A publicly traded corporation ("D") owns all the stock of a subsidiary corporation ("S"), which in turn owns all the stock of a controlled corporation ("C"). D, S, and C are members of the same affiliated group. In order to facilitate an acquisition by a third corporation ("P"), S distributes its C stock to D, and D then distributes its C stock to its shareholders. Within two years, P acquires all the stock of D in a section 368(a)(1)(B) reorganization, with the shareholders of D receiving 40 percent of the stock of P in exchange for their D stock.

## Section 355(f) Applies: Alternative

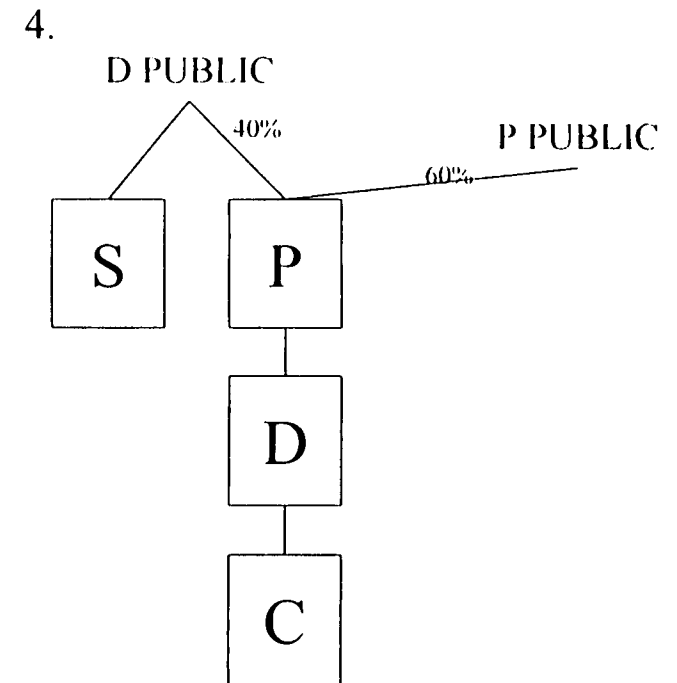
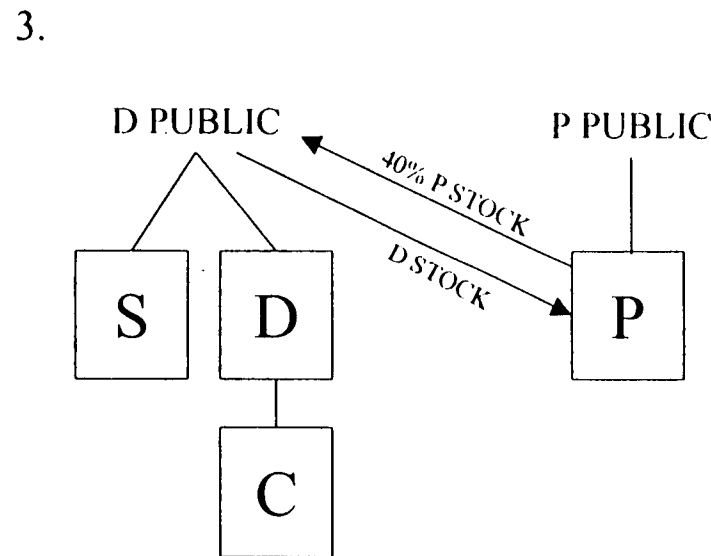
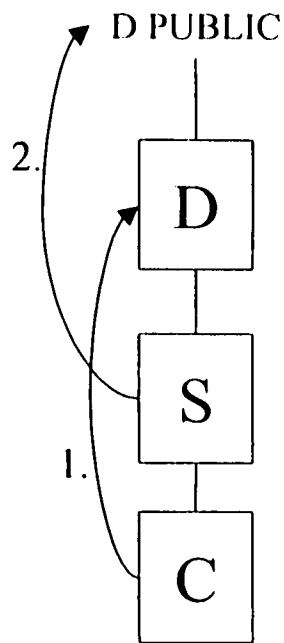

**FACTS:** Same facts as the first example, except that S distributes its C stock to D, D then distributes its S stock to its shareholders, and, within two years, P acquires all the stock of D in a section 368(a)(1)(B) reorganization, with shareholders of D receiving 40 percent of the stock of P in exchange for their D stock.



## Section 358(g)

1.

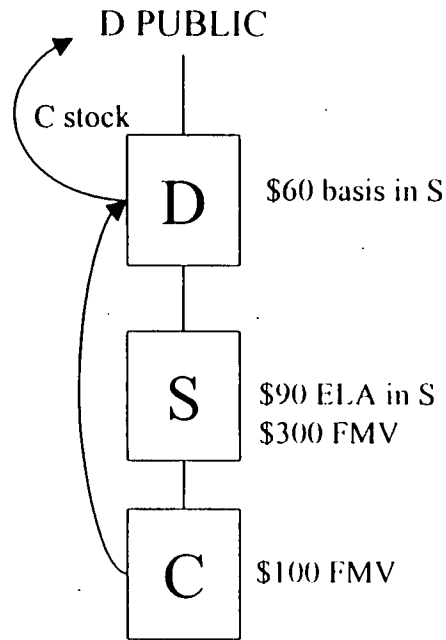

2.

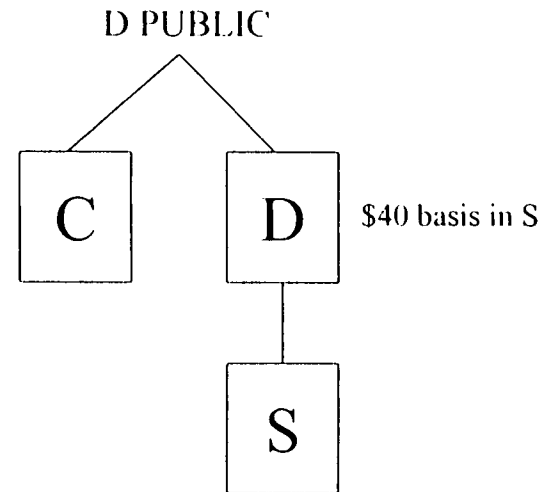

**FACTS:** A publicly traded corporation (“D”) owns all the stock of a subsidiary corporation (“S”), which in turn owns all the stock of a controlled corporation (“C”). D has a \$60 basis in the stock of S, and S has a \$90 ELA in the stock of C. S distributes all the stock of C to D. At the time of the distribution, the C stock is worth \$100, and the S stock is worth \$300 (including the stock of C).

# Section 355(d) In General

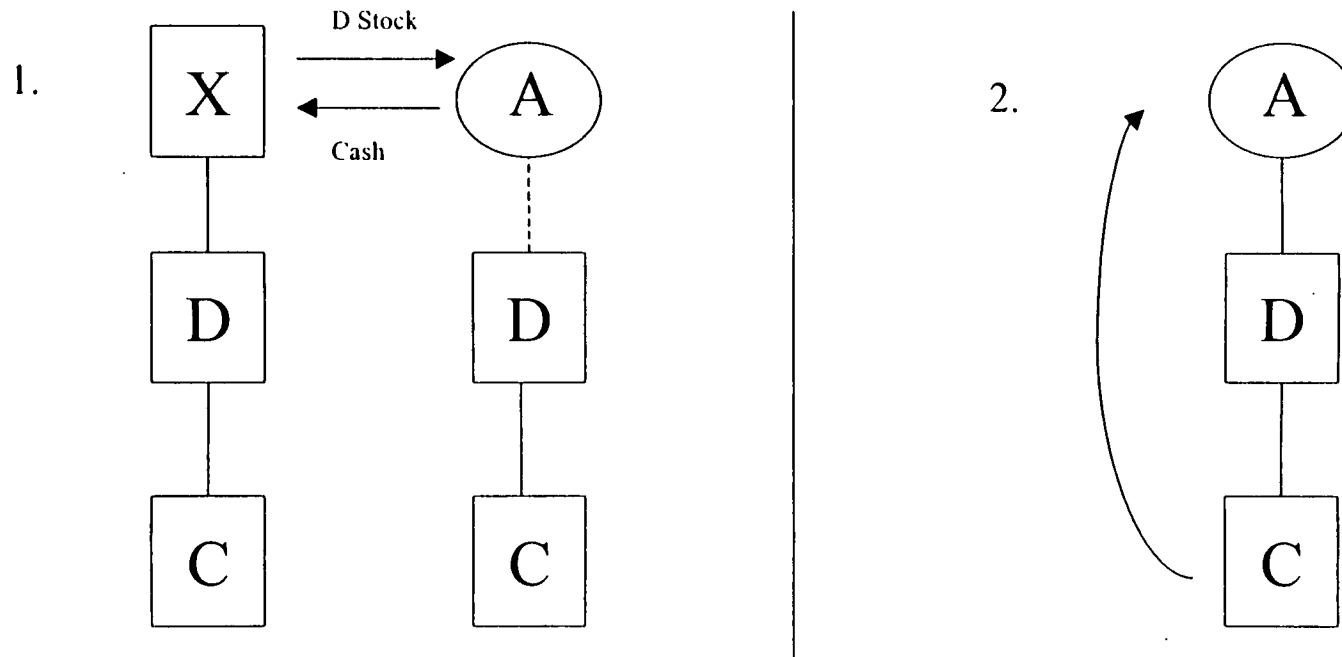

**FACTS:** D owns all the stock of Controlled (“C”). In Year 1, A purchases all the stock of D from X. In Year 4, D distributes all the stock of C to A in a transaction that meets the requirements of section 355(a).

# Multiple Spin-Offs (Triple Tax Potential)

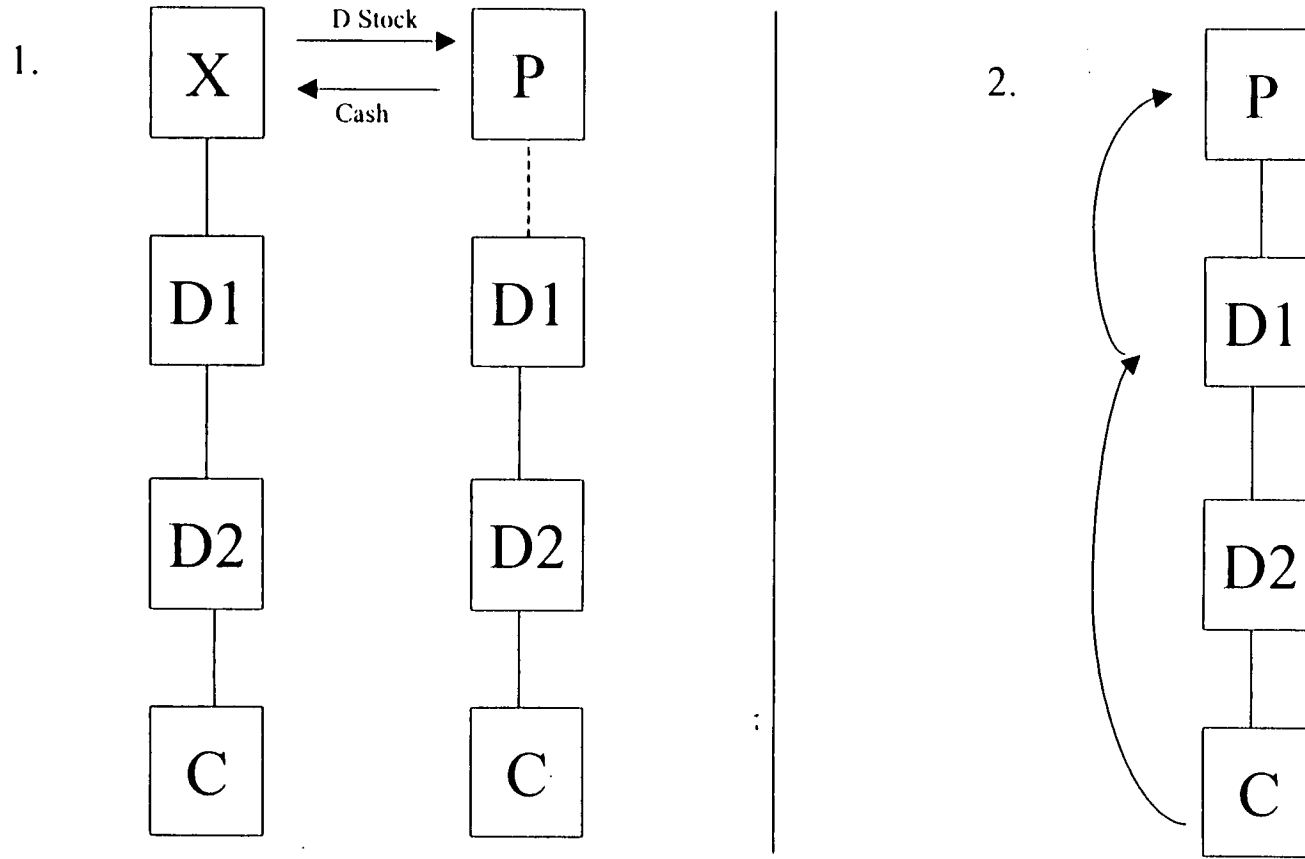

**FACTS:** D1 owns all the stock of D2, which owns all the stock of C. In Year 1, P purchases all the stock of D1 from X for cash. In Year 4, D2 distributes all the stock of C to D1, and later in Year 4, D1 distributes all the stock of C to P.

# Public Offering

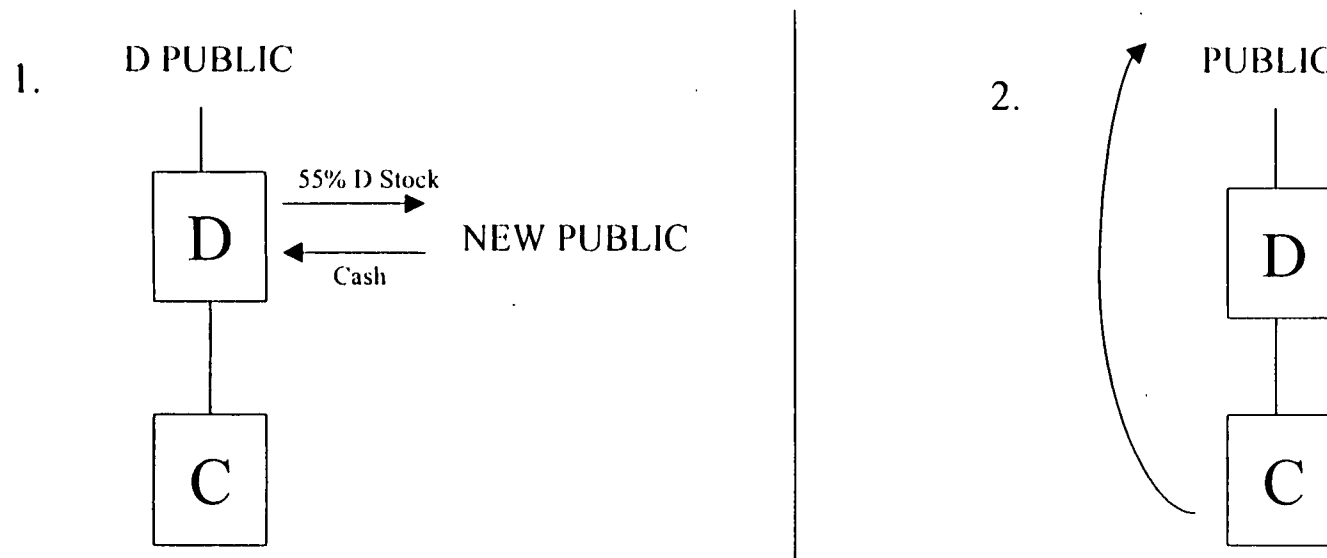

**FACTS:** D, whose stock is publicly traded, owns all the stock of C. In a public offering, D issues stock having 55 percent of its voting power. Four years later, D distributes all the stock of C to its public shareholders.

# Elimination of Basis -- Sections 355(d) and (e)

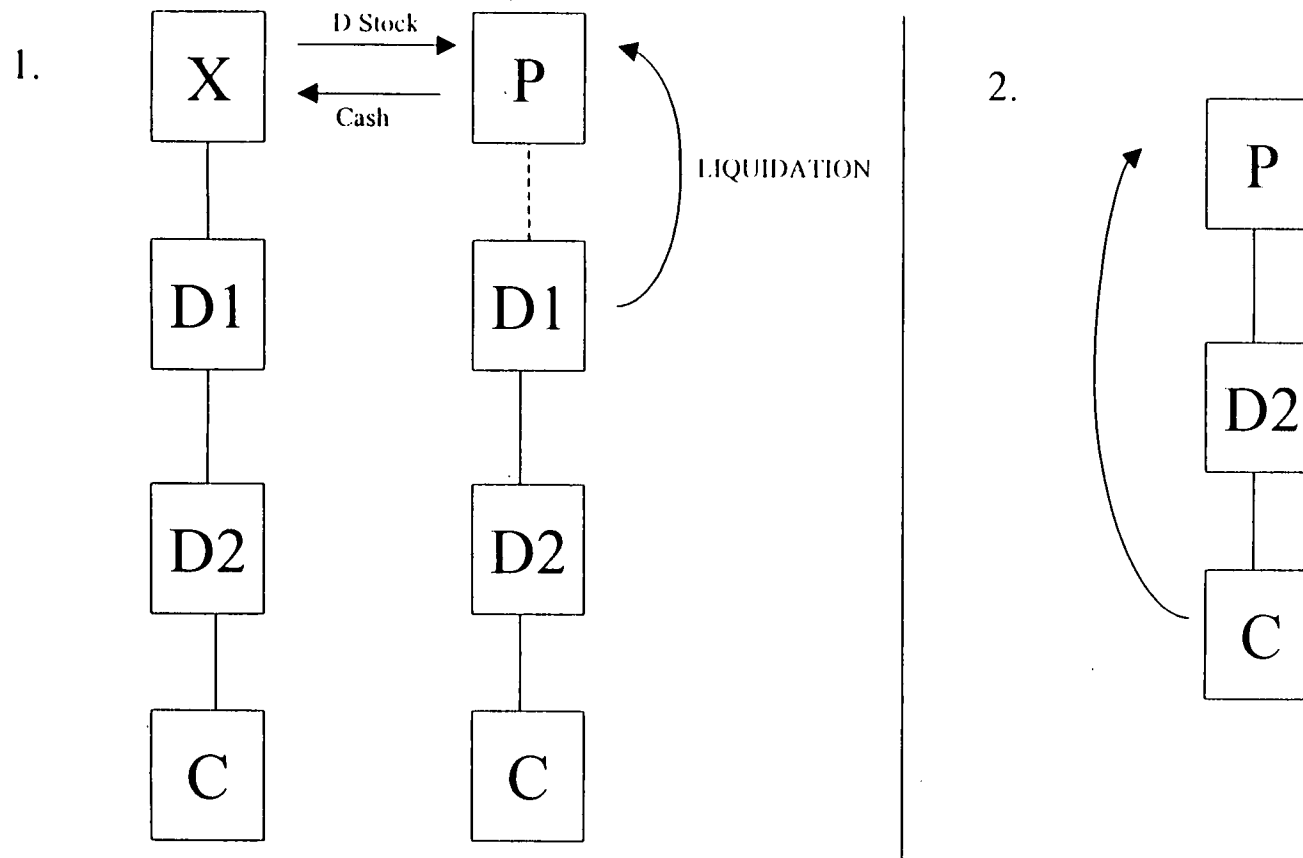

**FACTS:** D1 owns all the stock of D2, which owns all the stock of C1 and C2. In year 1, P purchases all the stock of D1 from X for cash. In planning its acquisition of D, P considers a spin-off of C1 because of incompatibility with P's business, but this idea is abandoned. In year 2, P liquidates D1 in a section 332 liquidation. In year 4, to effect state tax savings, D2 distributes all the stock of C2 to P.

# Purchase Taint from Tax-Free Transaction

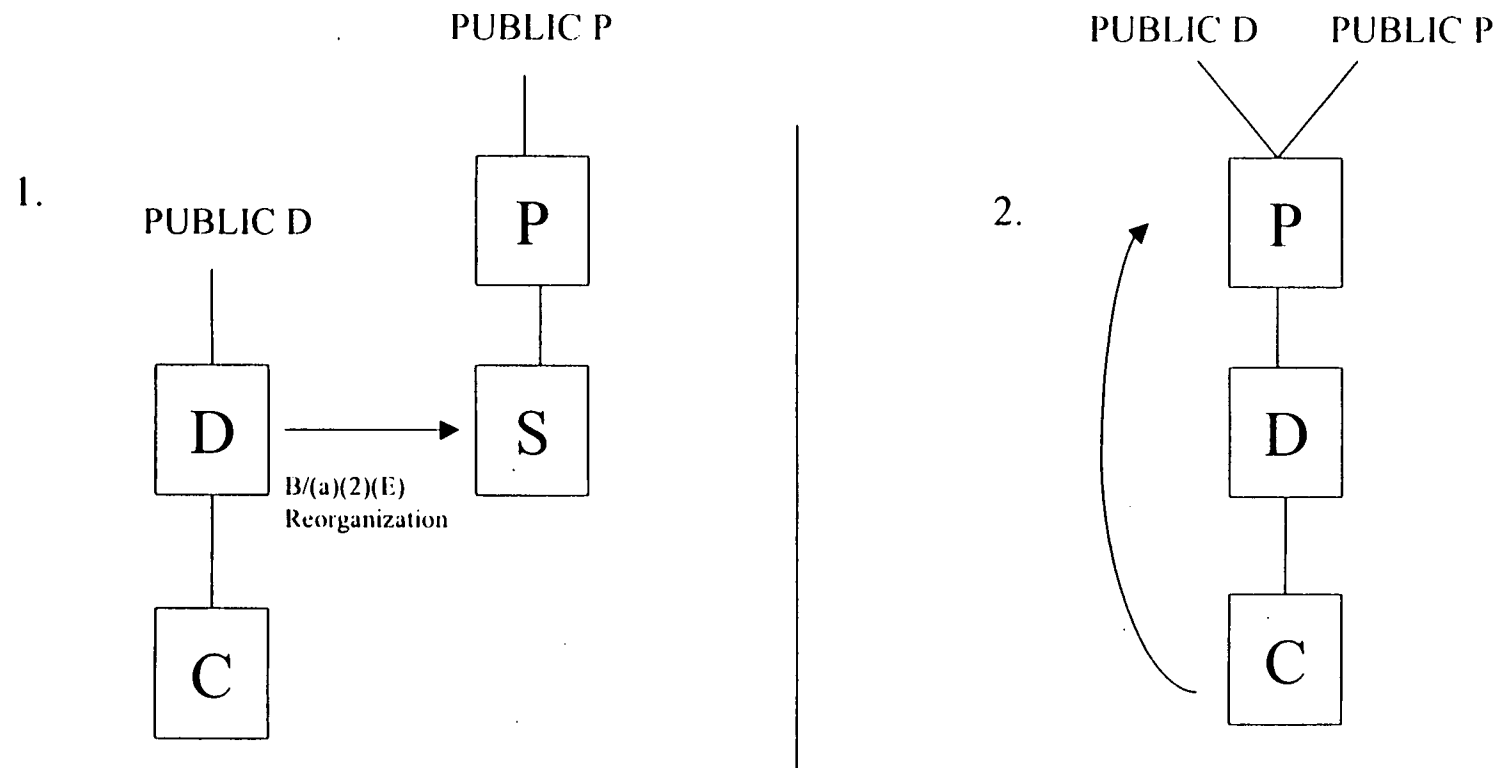

**FACTS:** The stock of D is publicly traded. D owns all the stock of C. P acquires all the stock of D in a transaction qualifying under section 368(a)(1)(B) and (a)(2)(E). Within the year before the acquisition, more than 50 percent of the D stock traded in market transactions. Four years later, D distributes all the stock of C to P.

# Holding Company Formation

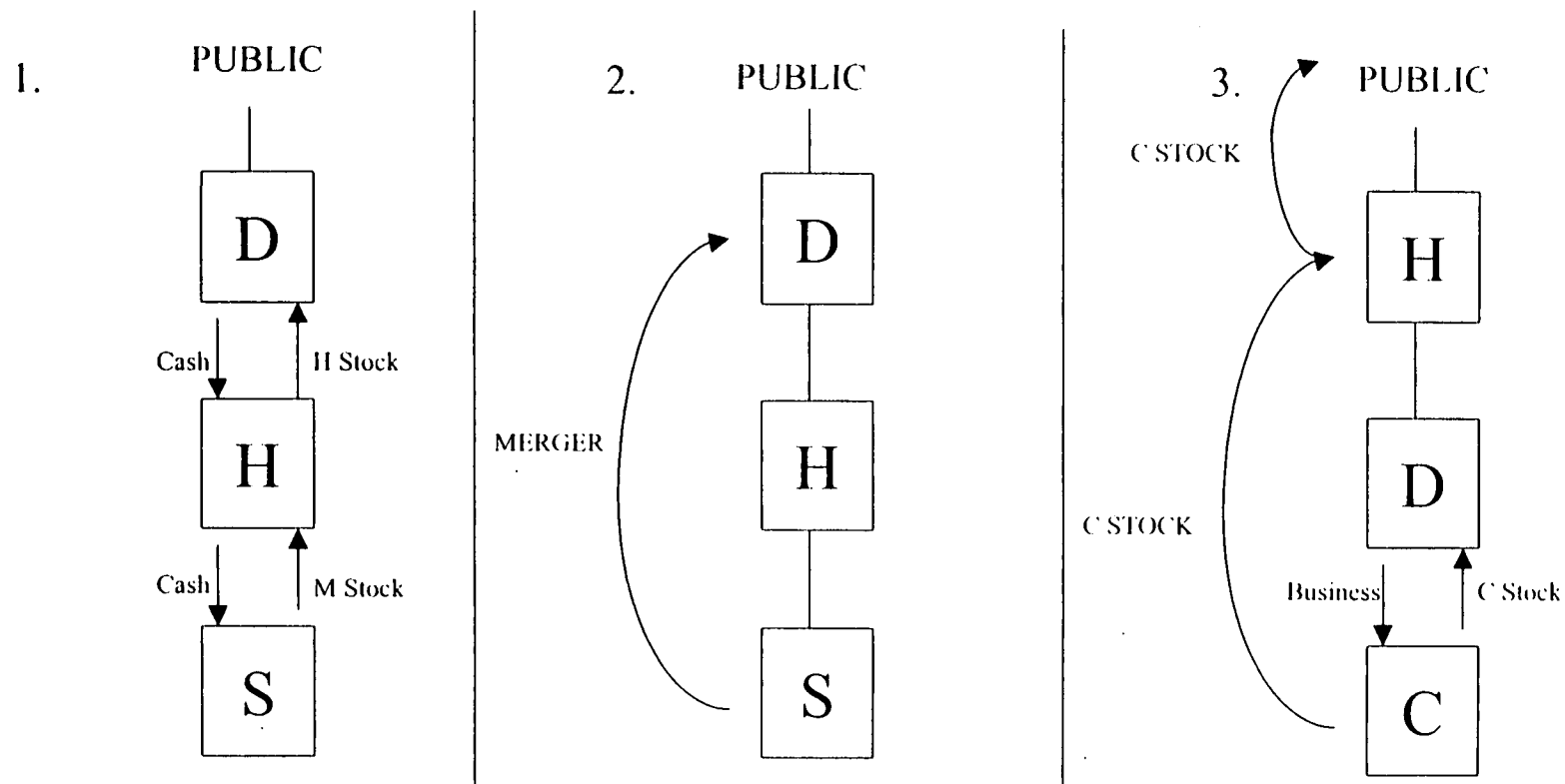

**FACTS:** The stock of D is publicly traded. D forms a H, which, in turn, forms S. S merges into D, with D's shareholders exchanging their D stock for H stock. Four years later, D drops a business into newly formed C and distributes all the stock of C to H, which, in turn, distributes all the stock of C to its public shareholders.

# Single Member LLCs In General

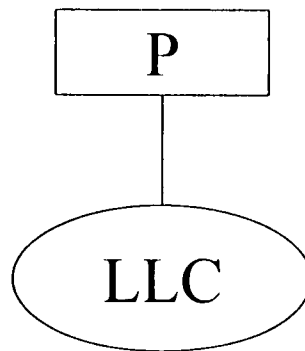

**Facts:** P owns all of the interests in an LLC. The LLC is disregarded as an entity separate from P for Federal tax purposes.

## **Advantages:**

1. Federal tax treatment as a division with limited liability for state law purposes.
2. Effective consolidation treatment without the need to comply with the consolidated return regulations.
3. Ability to use “grandparent” stock in triangular reorganizations.
4. Treatment of “start-up” costs as deductible expansion costs.
5. Availability of like-kind exchange treatment for exchanges involving interests in the LLC.
6. Achieve consolidated treatment and section 338(h)(10) results in states that do not recognize such treatment.



Disadvantages:

1. Certain LLCs cannot be parties to a tax-free reorganization.
2. Inability to conduct an IPO.
3. Lose basis in a corporate subsidiary if convert into an LLC.
4. Cannot spin-off an LLC.

# Multiple Disregarded Entities

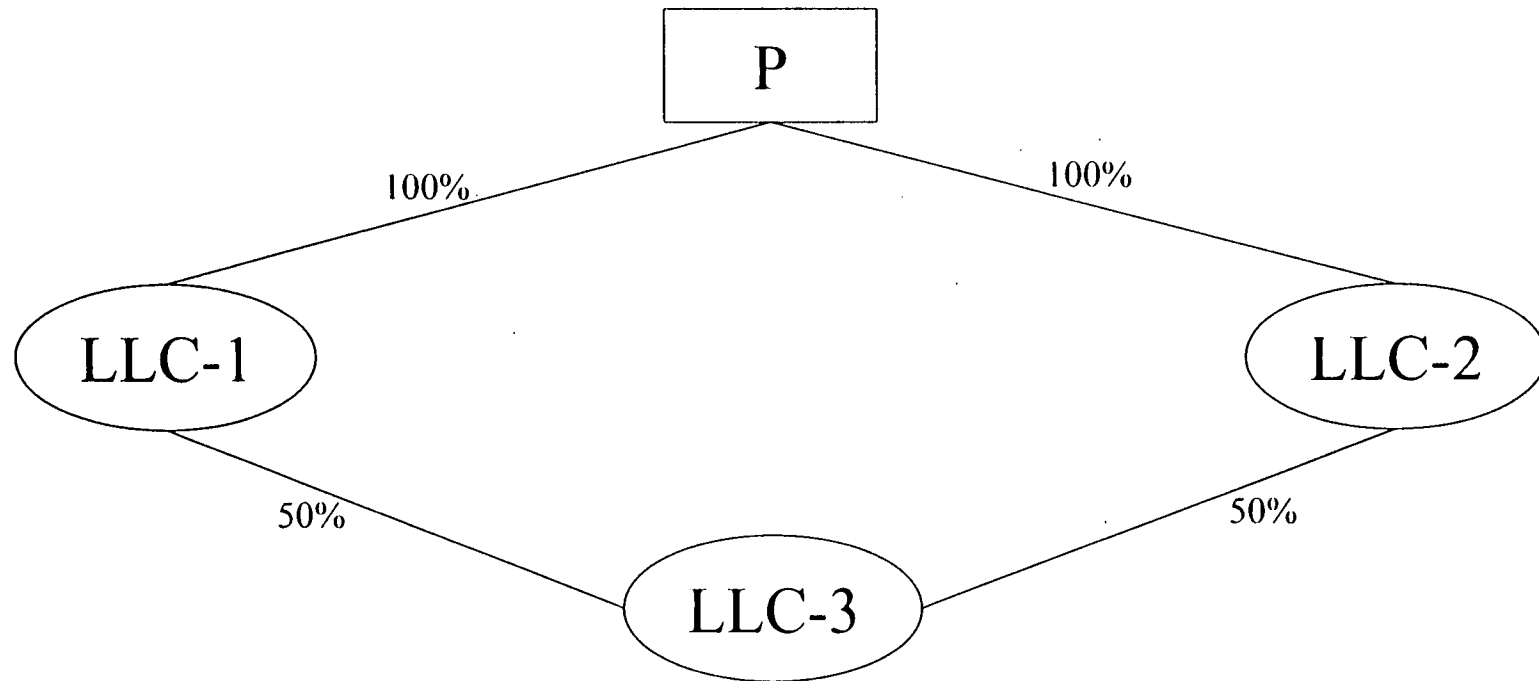

**Facts:** Corporation P is the sole member of LLC-1 and LLC-2, both of which do not elect to be taxed as associations. LLC-1 and LLC-2 form LLC-3, with each taking a 50 percent membership interest.

# Merger of Corporation Into Single-Member LLC

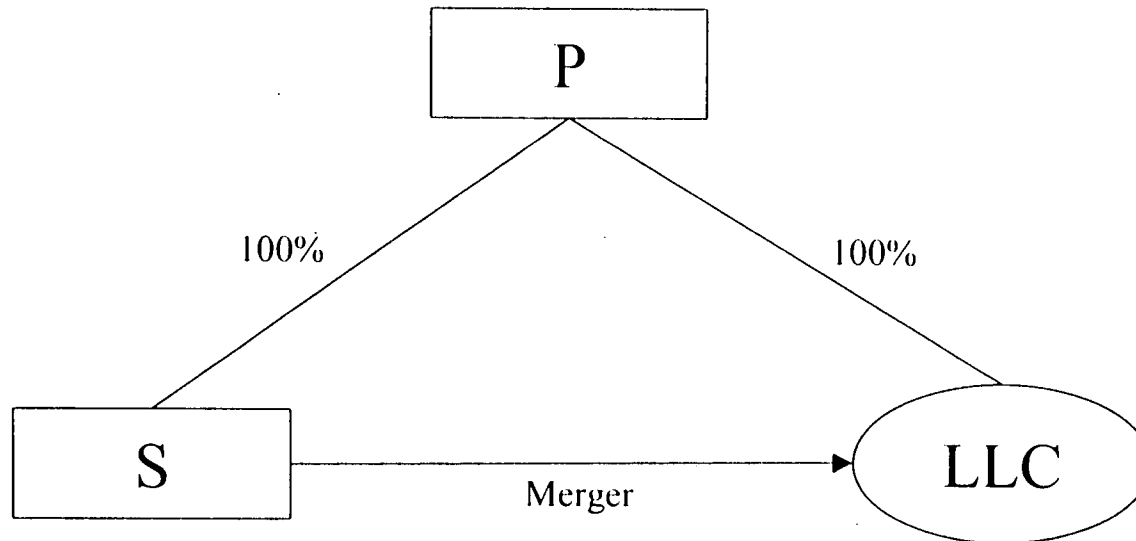

Facts: Corporation P owns all of the stock of S Corporation and all of the membership interests in LLC. LLC does not elect to be taxed as an association. S is merged into LLC pursuant to Delaware General Corporation Law section 264 (which permits the merger or consolidated of a Delaware corporation with an LLC). Pursuant to the merger, all of S's assets and liabilities are transferred to LLC, and S's separate corporate existence ceases. See P.L.R. 9822037 (Feb. 27, 1998).

# Sale of All of the Membership Interests

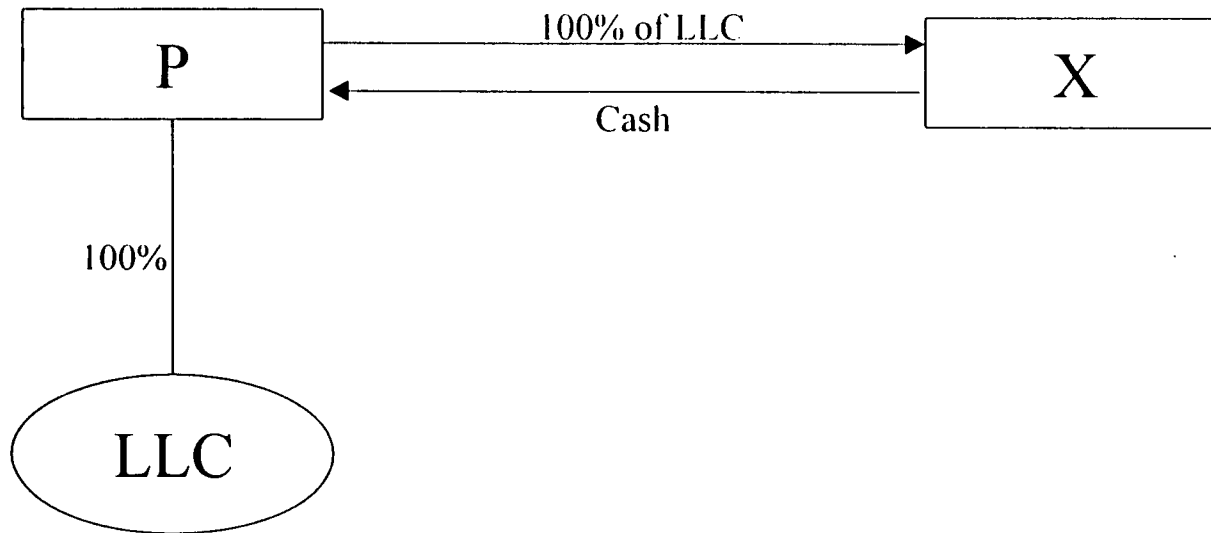

Facts: P owns all of the outstanding interests in LLC, which is treated as a disregarded entity for tax purposes. The fair market value of LLC's assets is \$100, and their adjusted basis is \$50. P sells all of the outstanding membership interests in LLC to X, an unrelated party, for \$100.

# Sale of Less than All of the Membership Interests

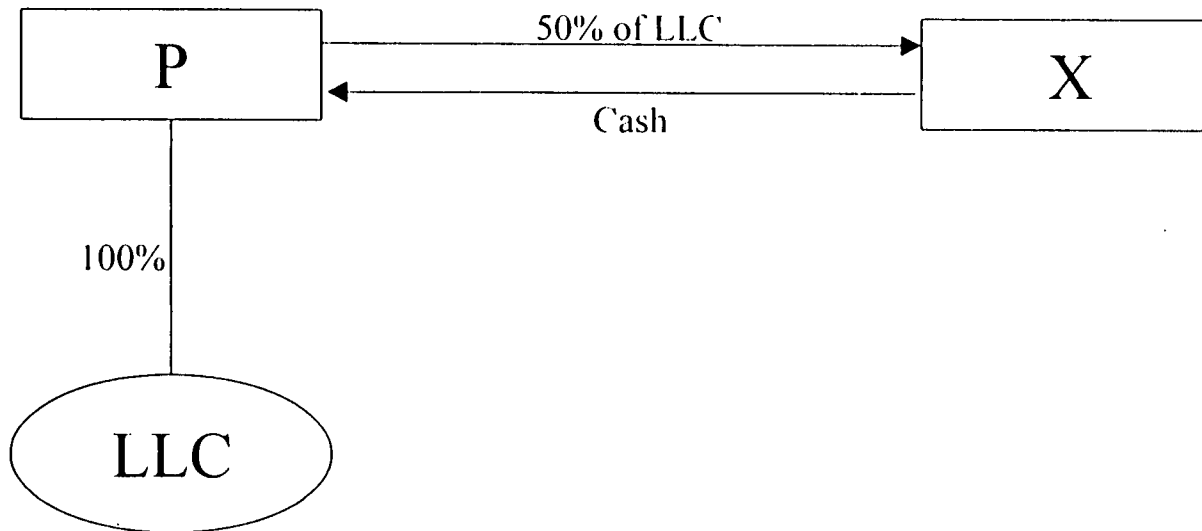

**Facts:** P owns all of the outstanding interests in LLC, which is treated as a disregarded entity for tax purposes. The fair market value of LLC's assets is \$100, and their adjusted basis is \$50. P sells 50 percent of the outstanding membership interests in LLC to X, an unrelated party, for \$50.

# Conversion of Multi-Member LLC Into SMLLC in Consolidation

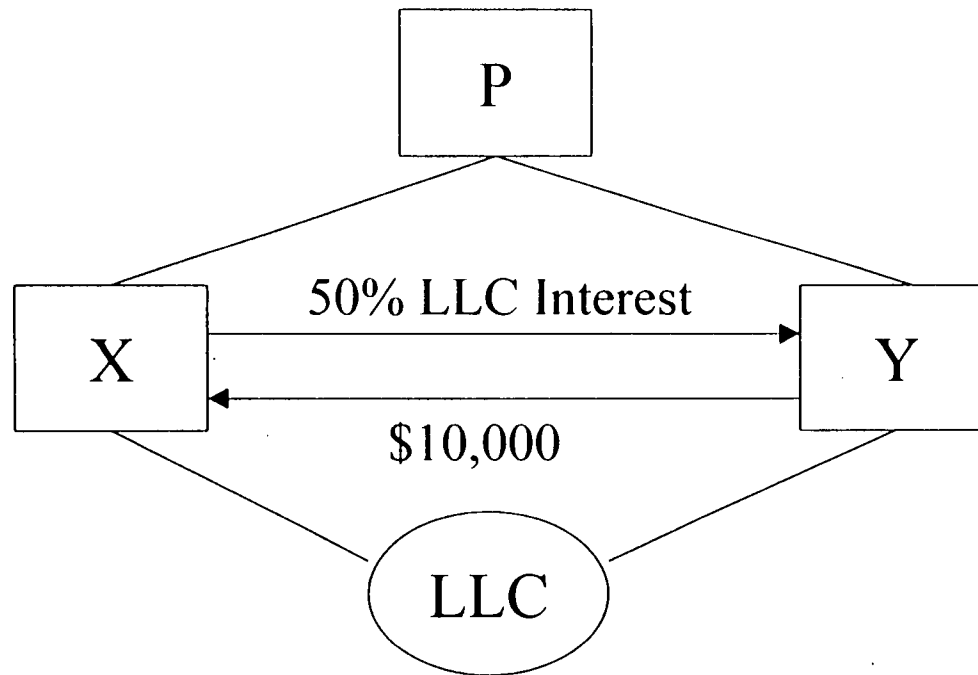

Facts: P owns all the stock of X and Y. P, X, and Y join in filing a consolidated return. X and Y each own a 50-percent interest in LLC. X sells its entire interest to Y for \$10,000. X has a \$5,000 basis in its interest in LLC. After the sale, the business is continued by LLC, which is owned solely by Y. LLC does not elect to be taxed as a corporation.

# Use of LLC's to Avoid Section 338(h)(10) Limitations

## Section 338(h)(10) Transaction

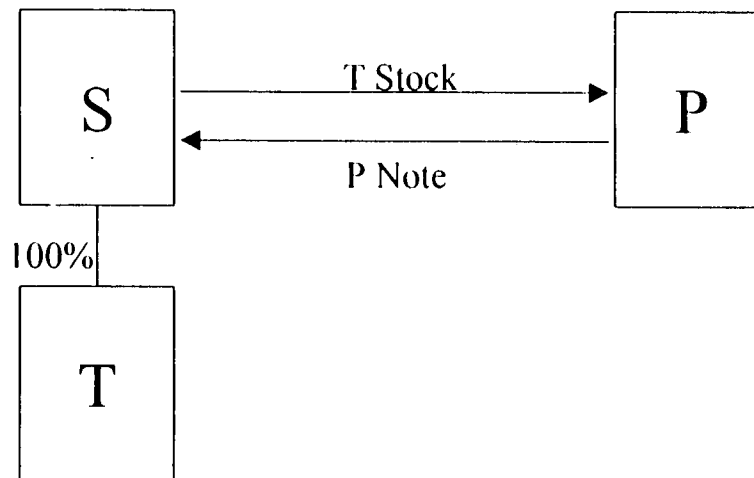

**Facts:** S owns all of the stock of T. S sells all of its T stock to P in exchange for a P note. S and P make a section 338(h)(10) election.

# Use of LLC's to Avoid Section 338(h)(10) Limitations Continued

## Section 338(h)(10) Transaction

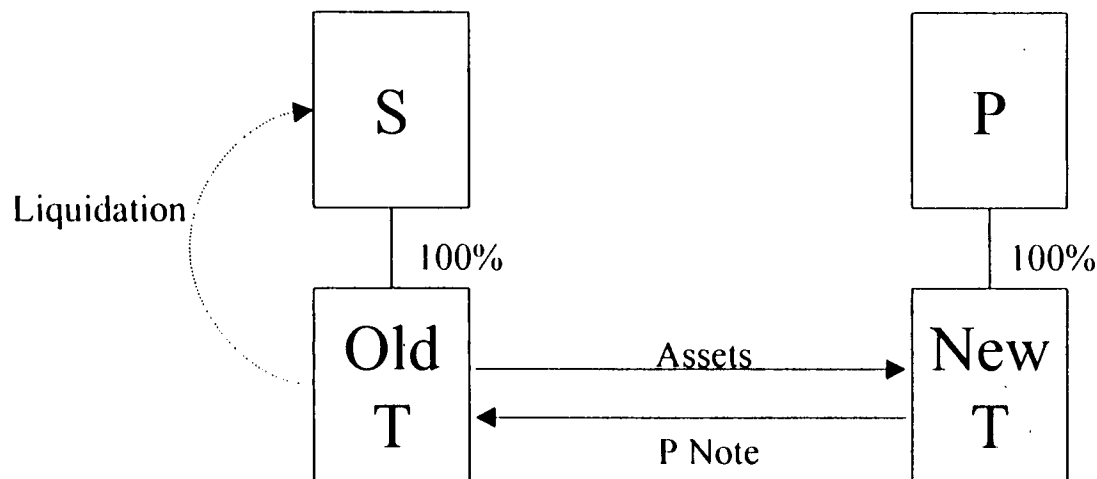

As a result of the section 338(h)(10) election, the parties are deemed to engage in a series of transactions: (1) The subsidiary (“Old T”) is treated as selling its assets to a new corporation owned by the acquiring corporation in exchange for a P note in a taxable sale; (2) Old T is treated as liquidating into its parent corporation.

Because the note is that of P rather than New T, it technically may not qualify for installment treatment under section 453.

Note that the proposed section 338 regulations permit the use of the installment method in section 338(h)(10) transactions. See Prop. Treas. Reg. § 1.338(h)(10)-1(d)(8).



# Use of LLC's to Avoid Section 338(h)(10) Limitations Continued

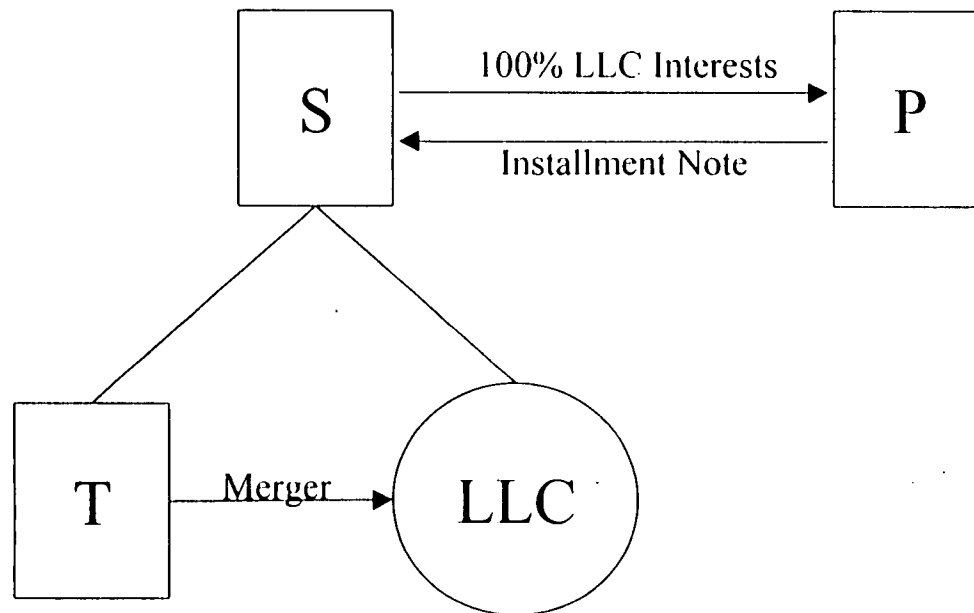

**Facts:** Corporation S owns all the stock of T. S forms a wholly owned LLC and merges T into the LLC. S then sells 100% of the LLC interests to P, an unrelated party, in exchange for an installment note of P.

# B Reorganization

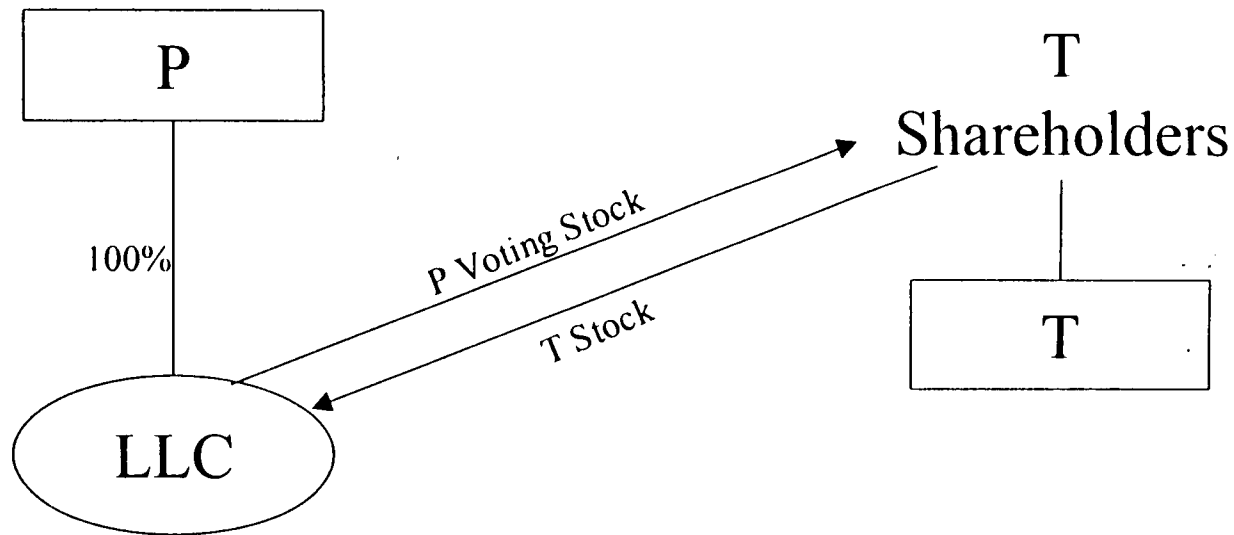

Facts: P forms a wholly owned LLC. LLC does not elect to be taxed as an association and is, thus, treated as a disregarded entity. LLC acquires T stock from the T shareholders in exchange for P voting stock.

# C Reorganization

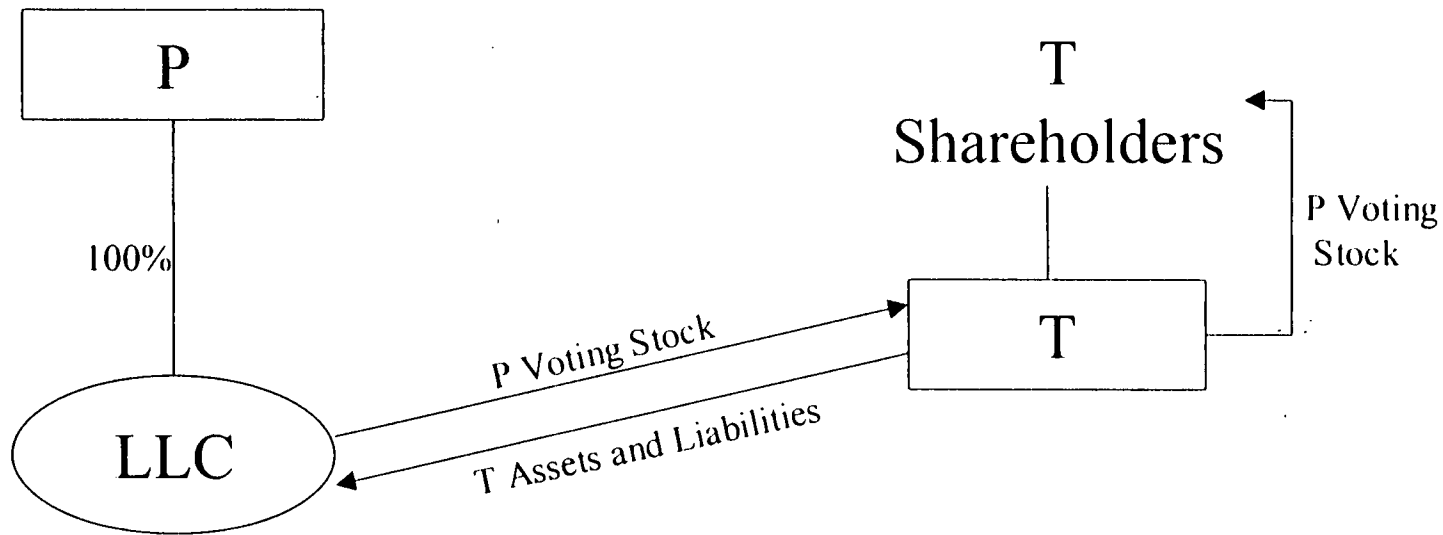

**Facts:** P forms a wholly owned LLC, which is treated as a disregarded entity, with P voting stock. P wants LLC to acquire T in a tax-free reorganization. T has assets worth \$100 and has recourse liabilities of \$30. LLC transfers its shares of P voting stock to T in exchange for all of T's assets and liabilities. T distributes all of the P voting stock to its shareholders in complete liquidation.

# A Reorganization

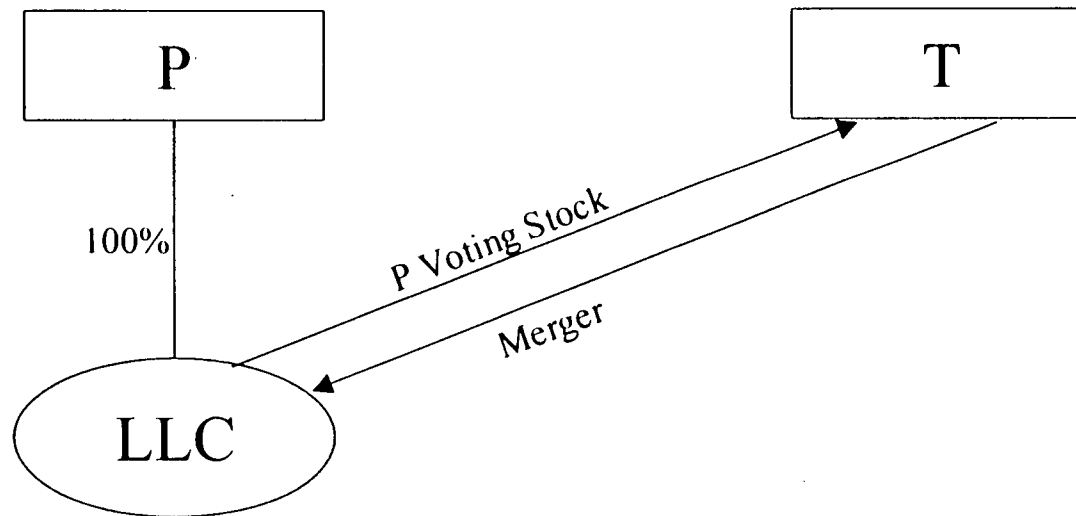

Facts: P forms a wholly owned LLC. LLC is treated as a disregarded entity. T merges into LLC pursuant to a state statutory merger, with the T shareholders receiving P voting stock.

# Downstream Merger into LLC

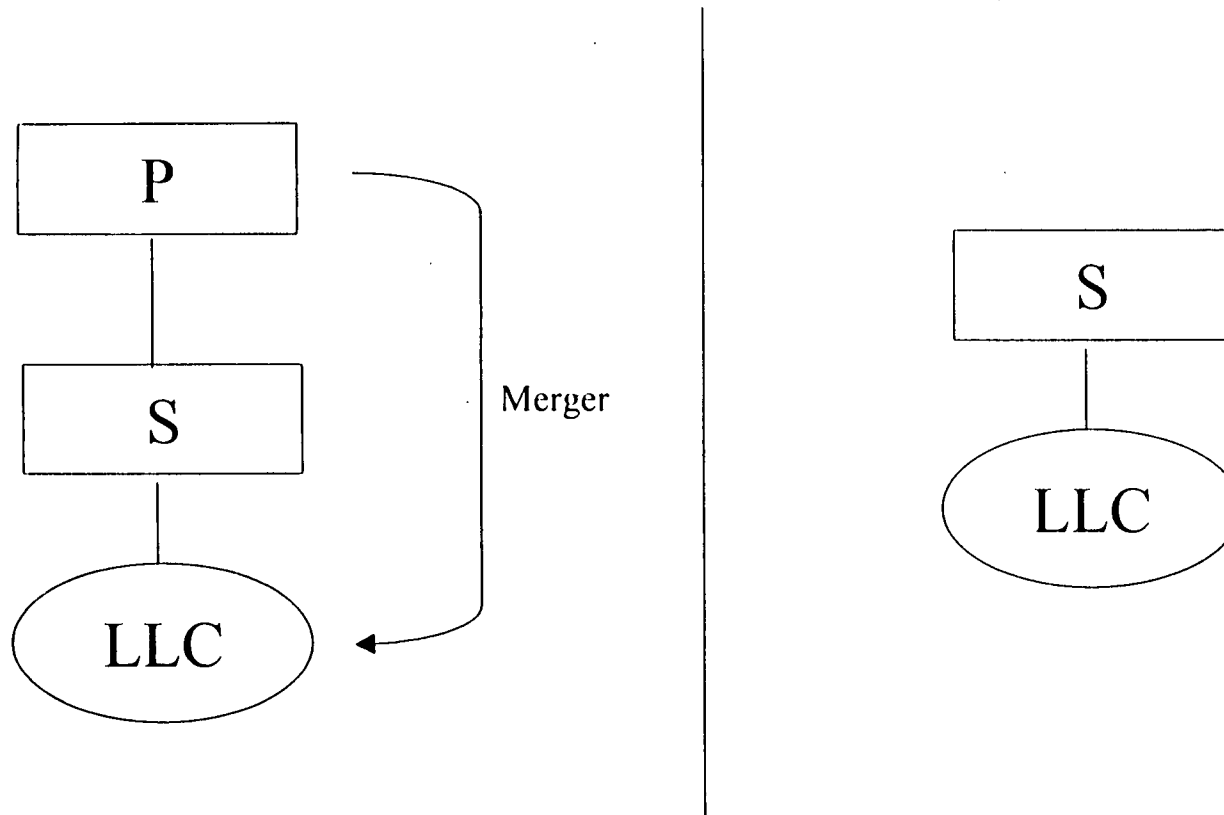

Facts: P owns all of the stock of S. P wants to merge downstream into S, but cannot do so because it violates certain loan covenants. S forms a single-member LLC, which is treated as a disregarded entity, and P merges into the LLC pursuant to state law, with the LLC surviving.

# Downstream Merger into LLC - Variation 1

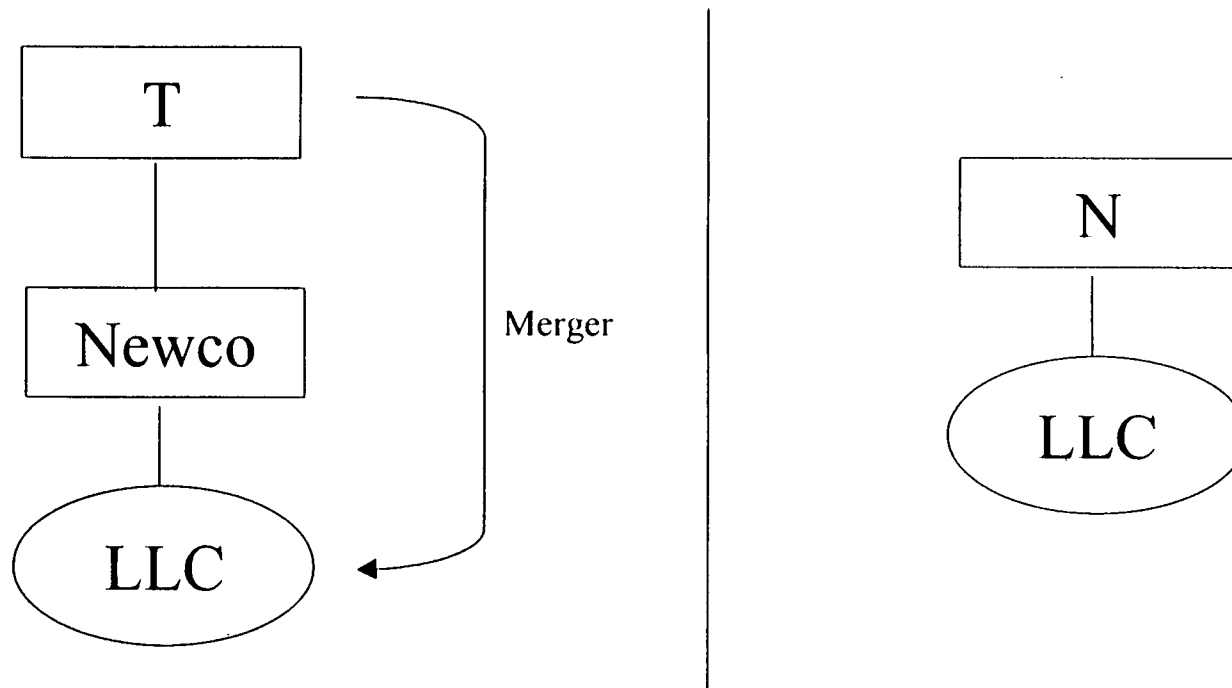

Facts: T wants to reincorporate in a different state. T forms Newco, and Newco forms a single-member LLC, which is treated as a disregarded entity. T merges into the LLC pursuant to state law, with the LLC surviving.

# Downstream Merger into LLC - Variation 2

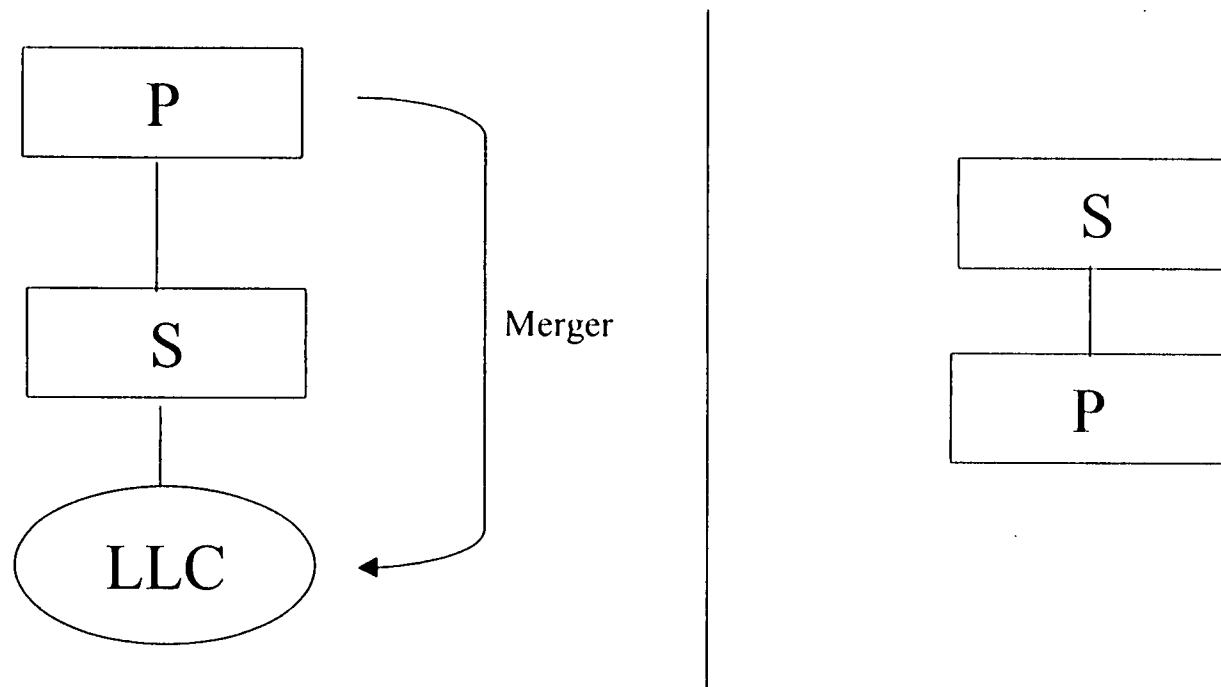

Facts: P owns all of the stock of S. It is desired that S be the parent company of P. S forms a single-member LLC, which is treated as a disregarded entity, and P merges into the LLC pursuant to state law, with P surviving.

# Intragroup A Reorganization

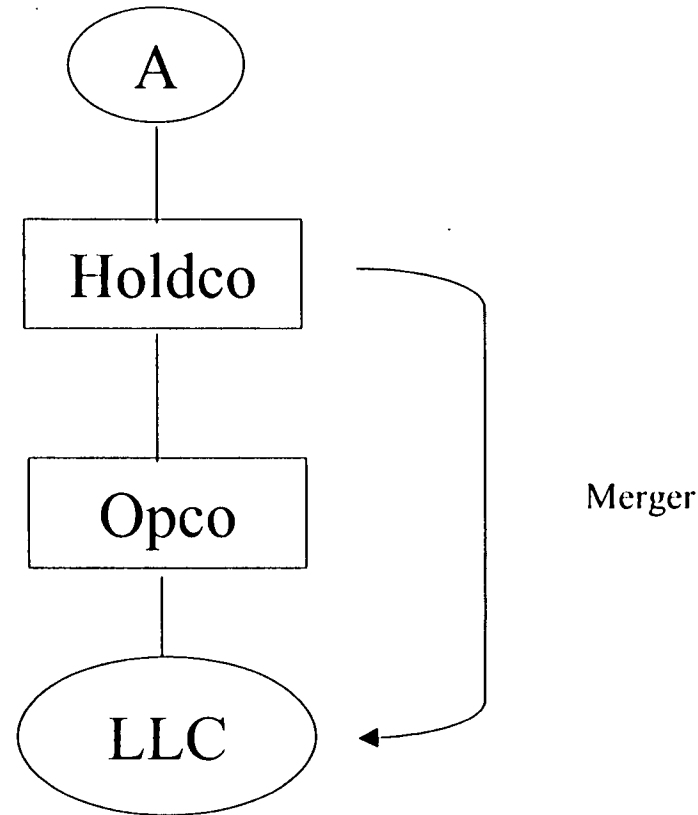

Facts: Individual A owns all of the stock of Holdco. Holdco is a holding company whose only asset consists of the stock of Opco, an operating company. Opco is insolvent. Holdco wants to merge downstream into Opco, but cannot do so because it violates certain loan covenants. Instead, Opco forms a single-member LLC, which is treated as a disregarded entity, and Holdco merges into the LLC pursuant to state law.



# Use of LLCs in Spin-Offs

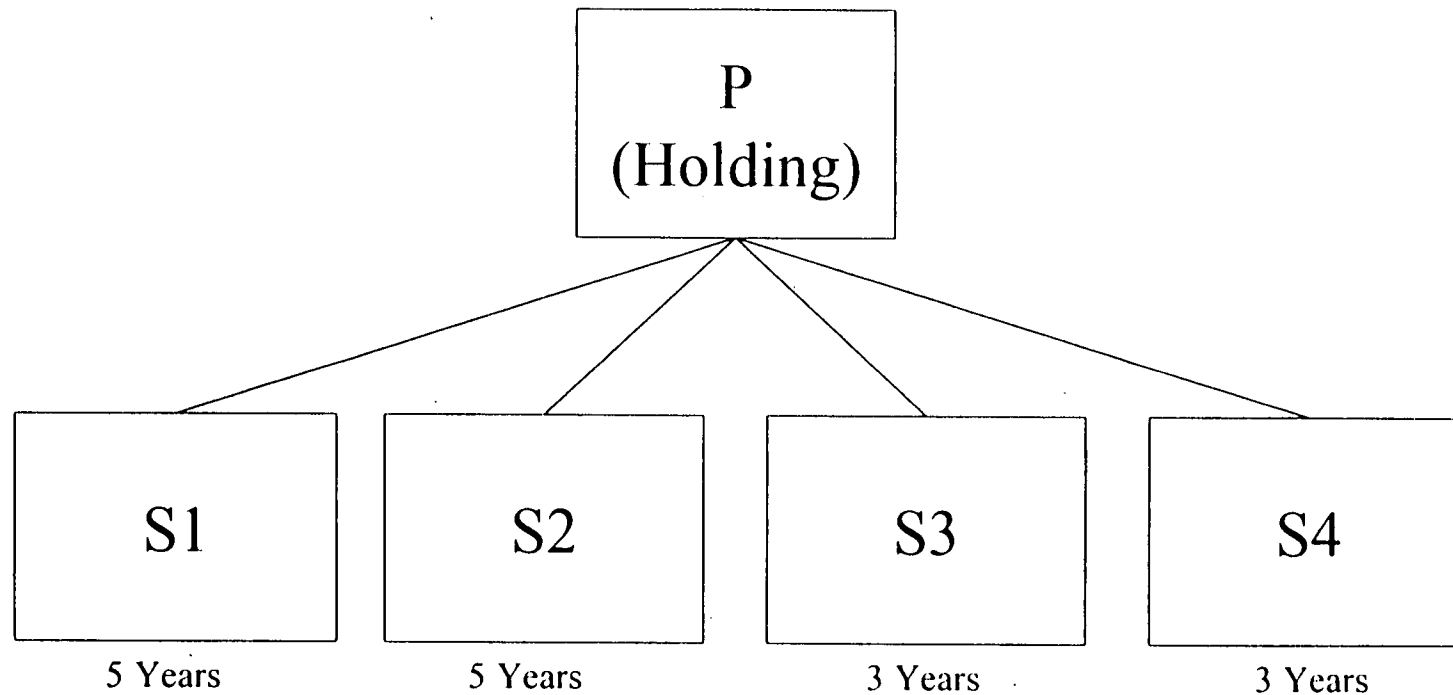

**Facts:** P, a holding company, has four wholly owned subsidiaries, S1, S2, S3, and S4. The subsidiaries are each actively engaged in a trade or business for purposes of section 355. S3 and S4, however, were acquired in taxable transactions during the past five years. As a result, S3 and S4 are not engaged in qualifying active businesses under section 355(b). S2 merges into an LLC. P then distributes the stock of S1 to its shareholders.

# Use of LLCs in Spin-Offs (Continued)

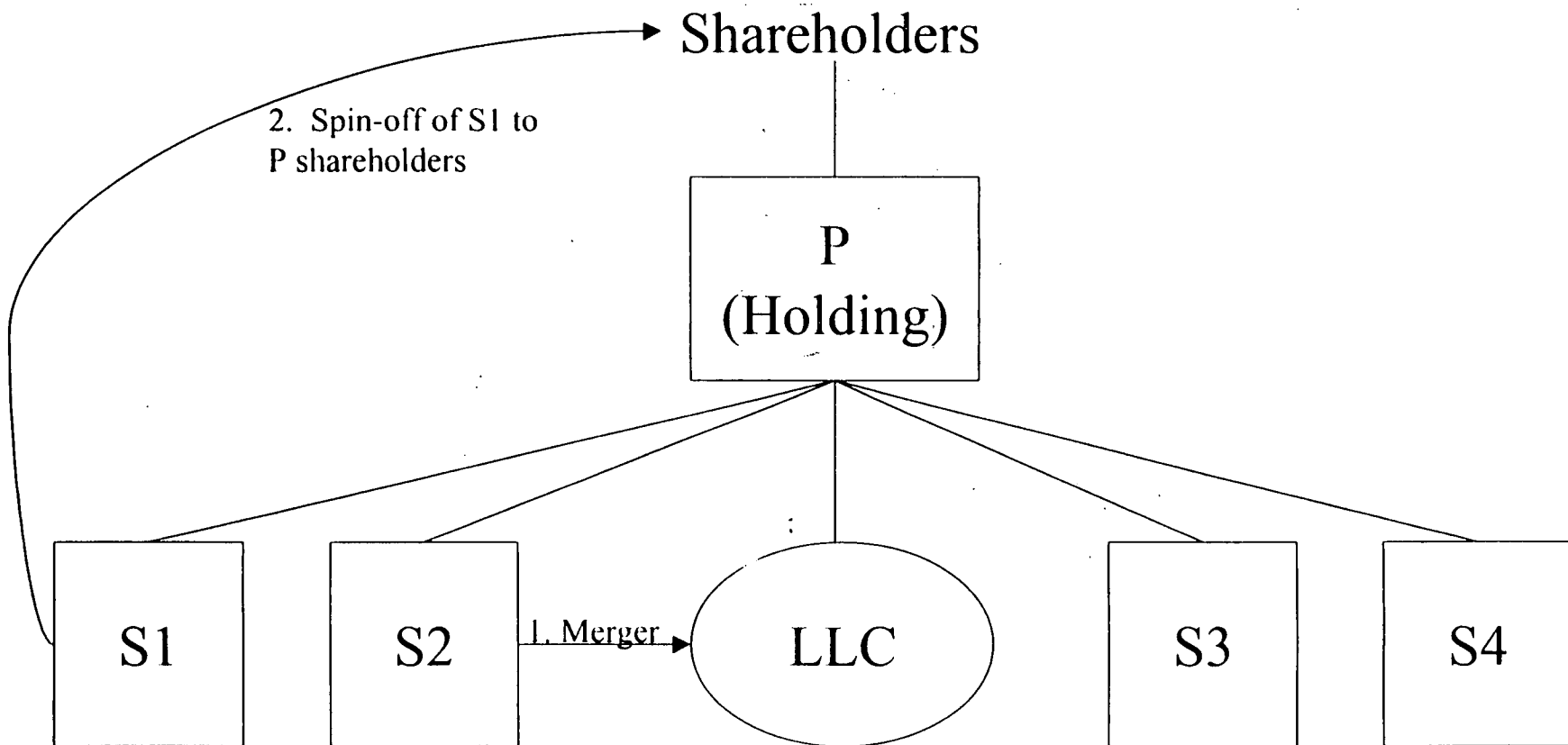

# Distribution of LLC Interests as a Spin-Off

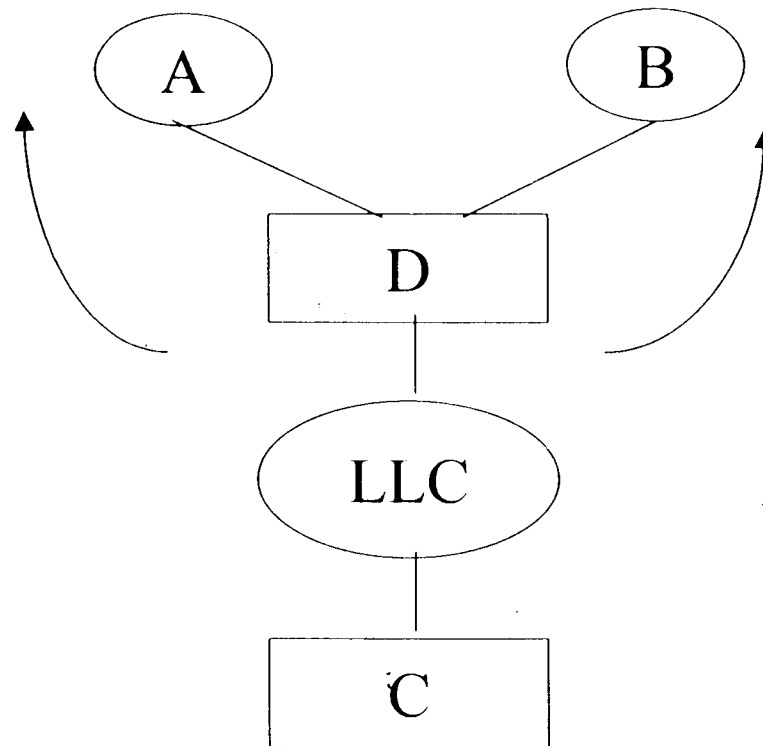

Facts: Individuals A and B own all of the stock of D. D owns all of the interests in LLC, which is disregarded as a separate entity. LLC owns all of the stock of C. D distributes all of the LLC interests to A and B.

# Avoiding the Requirements of Section 355

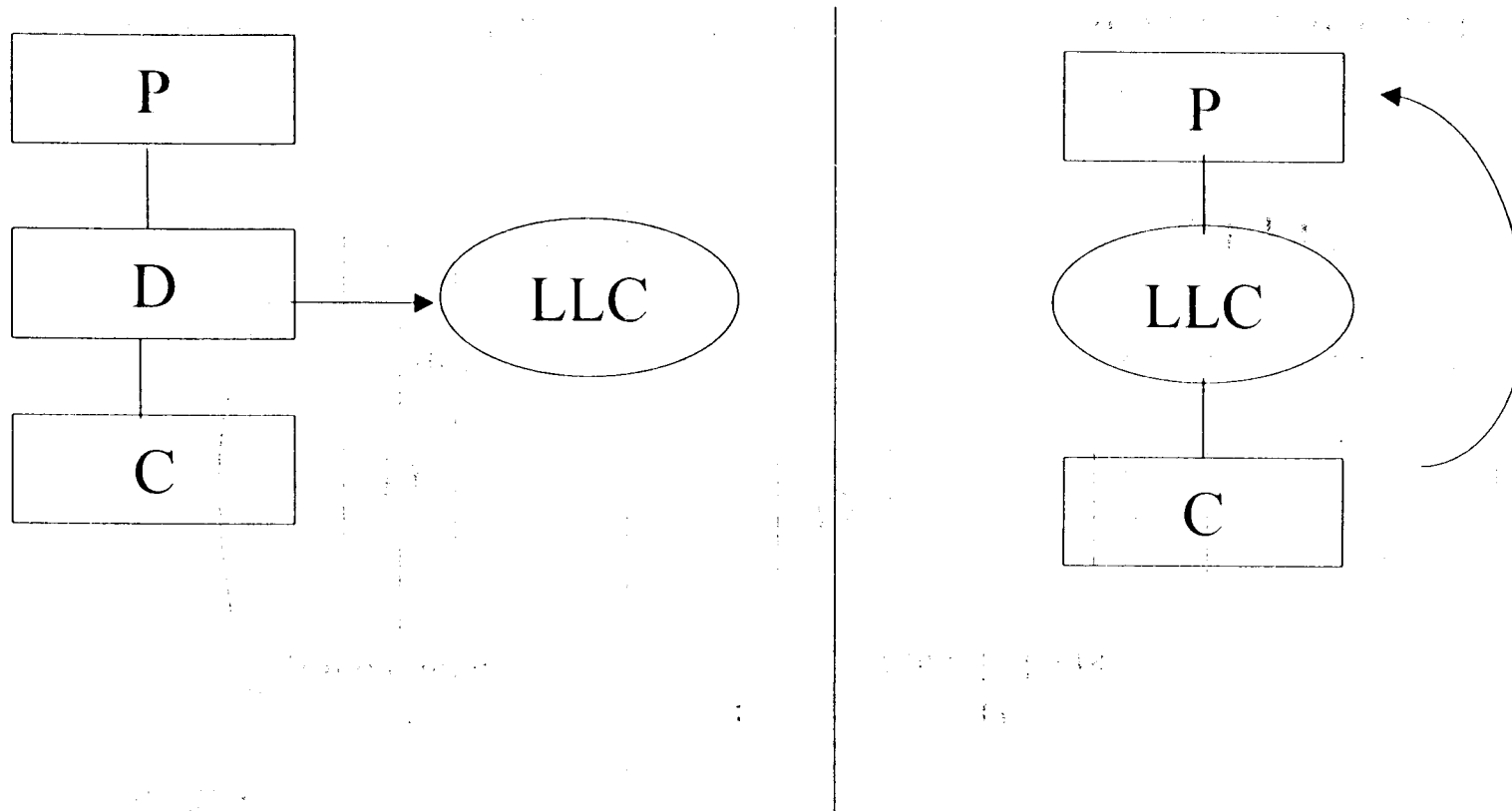

Facts: P owns all of the stock of D. D owns all of the stock of C. D wants to distribute C to P, but a section 355 spin-off is not available. P forms a single-member LLC, which is disregarded as a separate entity, and merges D into the LLC. LLC then distributes all <sup>142</sup> of the C stock to P.

# Section 355(e) Transaction

Step 1

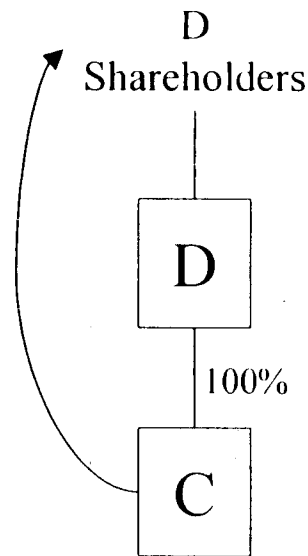

Step 2

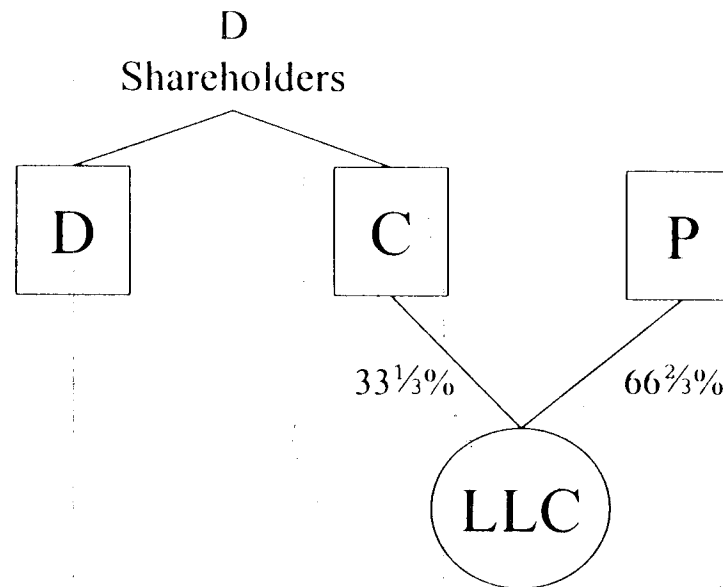

Facts: D distributes all of the stock of its wholly owned subsidiary, C, in a tax-free spin-off pursuant to section 355. Six months later, P offers to acquire the assets of C in a tax-free reorganization. C agrees instead to a transaction wherein it drops its assets into a newly formed LLC in exchange for a one-third interest in the LLC, and P drops some of its assets into the LLC in exchange for two-thirds of the interests.